

# Wireless World

Radio • Electronics • Electro-Acoustics

33rd YEAR OF PUBLICATION

NOVEMBER 1943

Proprietors :  
ILIFFE & SONS LTD.

Managing Editor :  
HUGH S. POCOCK,  
M.I.E.E.

Editor :  
H. F. SMITH.

Editorial, Advertising  
and Publishing Offices :

DORSET HOUSE,  
STAMFORD STREET,  
LONDON, S.E.1.

Telephone :  
Waterloo 3333 (35 lines).

Telegrams :  
" Ethaworld, Sedist, London."



PUBLISHED  
MONTHLY

Price : 1/6

(Publication date 25th  
of preceding month)

Subscription Rate :  
Home and Abroad  
20/- per annum.

EDITORIAL. Restarting Television .. ..	319
CINEMA SOUND QUALITY.	
By J. Moir, A.M.I.E.E. .. ..	320
RADIO DATA CHARTS—12.	
By J. McG. Sowerby, B.A., Grad.I.E.E. ...	324
NEWS IN ENGLISH FROM ABROAD .. ..	326
ELECTRONIC VOLTAGE REGULATORS.	
By F. Livingston Hogg. .. ..	327
COMMANDO SIGNALS .. ..	332
SINGLE-VALVE FREQUENCY DIVIDER.	
By Patrick F. Cundy, A.M.I.E.E., (G2 MQ) ..	335
" WIRELESS WORLD " BRAINS TRUST .. ..	338
LOW-TENSION SOLDERING IRONS .. ..	340
WORLD OF WIRELESS .. ..	342
LETTERS TO THE EDITOR .. ..	344
RECENT INVENTIONS .. ..	346
RANDOM RADIATIONS. By " Diallist " .. ..	348
UNBIASED. By Free Grid .. ..	350

Branch Offices :

COVENTRY :

8-10, Corporation Street.  
Telephone : Coventry 5210.

Telegrams :  
" Autocar, Coventry."

BIRMINGHAM :

Guildhall Buildings,  
Navigation Street, 2.

Telephone :  
Midland 2971 (5 lines).

Telegrams :  
" Autopress, Birmingham."

MANCHESTER :

260, Deansgate, 3.

Telephone :  
Blackfriars 4412 (4 lines).

Telegrams :  
" Iliffe, Manchester."

GLASGOW :

26B, Renfield Street, C.2.

Telephone : Central 4857.  
Telegrams : " Iliffe, Glasgow."



As many of the circuits and apparatus described in these pages are covered by patents, readers are advised, before making use of them, to satisfy themselves that they would not be infringing patents.

## " HYPERLOY "

### TRANSFORMERS AND CHOKES

A range of high-performance, space-saving Components designed to meet the most exacting requirements of modern Electronic and Communications equipments.

- Small in size
- Weighing only 2 oz.
- Meeting the most rigid Tropical Specification
- Easily mounted in any position
- Manufactured in a variety of windings to meet many diverse applications

★ Owing to wartime restrictions on supply of raw materials, it is not possible to supply Wearite Components for purposes other than those connected directly with the war effort.

**WRIGHT & WEAIRE LTD.**  
HIGH ROAD, TOTTENHAM, N.17

Telephone: TOTTENHAM 3847-8-9





## X-Rays

There are no fanfares for him; no news-reels show him in action; he wields no weapons more lethal than a slide-rule. But he is instrumental in placing a great invisible power in the hands of others.

He—and his colleagues of the research and development laboratories—have made it possible to see deep into the heart of the metal of vital things like aero engines and gun barrels, to make sure that no hidden flaws exist; they have

given to doctors and surgeons an ally of ever-increasing power and scope for diagnosis and cure; to them belongs much of the credit for the part which mass radiography will play in the final elimination of the scourge of tuberculosis.

He and his colleagues have contributed greatly to Philips leadership in the field of X-rays. Their knowledge and experience are of vital importance to the nation today.

# PHILIPS



## RADIO ★ LAMPS

### AND ALLIED ELECTRICAL PRODUCTS

PHILIPS LAMPS LTD., CENTURY HOUSE, SHAFTESBURY AVENUE, W.C.2 (28D)

# Wireless World

Radio • Electronics • Electro-Acoustics

Vol. XLIX. No. 11

NOVEMBER 1943

Price 1s. 6d.

## Restarting Television

### *A No. 1 Post-war Priority*

IT is perhaps significant, and certainly gratifying, that several prominent figures in the world of wireless have, in recent public pronouncements, made more than passing reference to the problems involved in restarting our television service. That the service should be restarted with a minimum of delay when the war ends will, we think, be generally agreed in wireless circles, but perhaps not quite so readily among the general public or even by the Government. In a period of shortages—and we can expect them to persist for some time after the war—it can be argued with every show of plausibility that a form of entertainment with a very limited audience is by no means a “No. 1 priority.” But to do so is to take a very short view; it would be a thousand pities if we were to lose through niggardliness the lead in television established before the war. In any case, television is likely to develop into something much greater than a vehicle for light entertainment, and we feel no shame in pleading for the diversion of the tiny fraction of our national resources necessary for its early re-establishment.

To ensure a quick start, a decision must be made at once on the standards of transmission to be adopted. The alternatives before us have been clearly stated by the Deputy Director-General of the B.B.C., and are reported elsewhere in this issue. Briefly, we can reinstate the service almost at once with virtually 1939 standards, or we can wait for a considerable time until a much more advanced system is put into operation. Sir Noel Ashbridge stressed the fact that there is no worth-while middle course or compromise. Accepting that, it seems easy to make a choice; let us begin where we left off; any kind of service is better than no service at all. But that is not the whole story.

The arguments for and against retaining the pre-war standards for immediate post-war use were ably presented by T. E. Goldup in his recent inaugural address as Chairman of the Wireless Section of the I.E.E. In support of the “ready-made” system, he pointed out that the carrier frequency employed (45 Mc/s) gives a minimum of

trouble from echoes, and allows standard valve types to be used in receivers, for which the manufacturing technique is already well established. Further, the system probably lends itself quite well to extension to the provinces.

In discussing points in favour of an improved system, Mr. Goldup put improved definition, of a standard comparable with that of the cinema, as the main factor. That implied an increase in bandwidth and carrier frequency, the practical adoption of which depend “upon a large number of very controversial technical considerations.” Experimental work in this direction was welcomed as likely to lead, not only to improved definition, but also to colour representation and a wider range of subjects for the television camera.

Mr. Goldup then put forward a suggestion that we think, if it were given effect, would have the desired results of “getting things moving” and stimulating public interest and support. He said: “Those who are expert in the problems of television transmission and reception realise the magnitude of the problem of increasing picture definition, and it may be best in the immediate post-war period for the old television system to be run side by side with an improved system in an experimental stage. Then by gradual solution of the technical problems, this improved system may finally arrive at a stage fulfilling all the requirements of high definition and having regard in addition to the economics of the problems.”

To that suggestion we would make only one addition—and that not an original one. It has, we believe, already been suggested that, should it be decided to embark on a transmission system of higher definition, it should be conducted during the experimental period as a parallel service, but that a provincial area should be used as a testing ground. Naturally, the area would be carefully chosen to give the benefit of the service to the greatest density of population. The “London service” would, of course, be carried on with existing standards until such time as a national standard was decided upon.



# CINEMA SOUND QUALITY

## Investigating the Causes of Good and Bad Reproduction

THE quality of the sound in cinemas has often been the subject of criticism, sometimes with justification, but the writer thinks that critics are in error in trying to place the general responsibility on any one link in the chain, believing that trouble is produced all the way from the recording company that "cooks" the recording amplifier characteristic to suit their own particular reproducer (deficient in "top" response) to the cinema proprietor who expects the underpaid and overworked operator to service the fairly intricate electro-mechanical equipment responsible for the sound.

By

J. MOIR, A.M.I.E.E.

(Research Dept., The British Thomson-Houston Co., Ltd.)

cedure and after installation complete overall checks were carried out by the outside construction staff to make certain that an unlucky combination of tolerances had not resulted in something unsatisfactory.

In spite of these precautions the deserved uniformity in sound quality was not obtained, and it was decided to investigate the problem. In so far as the re-

outside staff to give us their opinion on the cinemas in their district, classifying them as "above average," "average" and "below average." This step was taken to eliminate as far as possible personal preference in the matter of sound quality and to reduce the effect of variation in sound recording. Experience has shown that it is unwise to criticise the sound in a cinema on the results of one film, unless that film has been used for quality tests previously and the results are well appreciated.

Generally we found that where sound was adversely criticised, the "intimacy" was said to be poor. Intimacy is difficult to define, but is here understood to indicate the closeness of association of sound and picture. When intimacy is poor it is difficult to define the sound source as being coincident with the picture action. The critic is uncertain of the reason for the poor sound, while being perfectly certain that it is unsatisfactory.

Intimacy or accurate sound focus must be fully understood

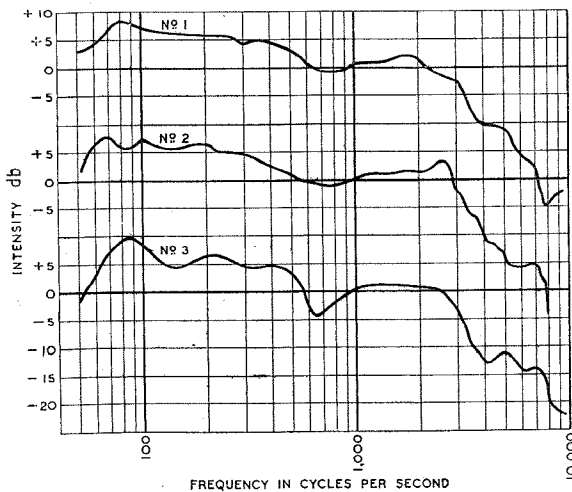

(Left) Fig. 1. Frequency characteristics in three typical theatres. Although the curves are similar the sound in theatre No. 1 was excellent throughout, No. 2 was generally below average and No. 3 was good in parts.

The results that are to be described were the outcome of an investigation into only one aspect of the problem, the question as to why identical reproducers exhibited such widely varying results when installed in different cinemas.

By 1936 the company with which the writer is associated had installed a very considerable number of identical reproducers in cinemas of many different designs with results which differed all the way from being very satisfactory to, shall we say, not so satisfactory. During manufacture the individual sections of the equipment were held to close tolerances by a rigid test pro-

(Right) Fig. 2. Frequency characteristics in different parts of the theatre No. 3 in Fig. 1. Curves (a) and (b), sound quality good. Curves (c) and (d), quality inferior.

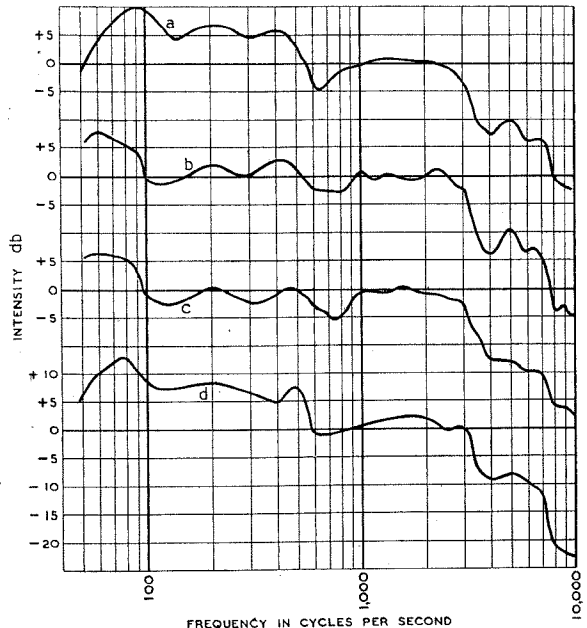

ducers were all of the same type and in good adjustment, the problem in this instance was largely acoustical.

The first step was to ask the

and achieved if stereophonic sound is to have practical applica-

tion in the cinema, because the fundamental requirement of stereophonic sound is that movements of the sound focus across

the good and bad positions in theatre No. 3 (Fig. 2). Indeed it is worthy of comment that in the first five cinemas checked the

sound quality was almost inversely proportional to what might have been expected from the critical study of the frequency characteristics alone. This result led to prolonged checking and rechecking

none of the characteristics obtained in the cinemas compares even remotely with the normal axial frequency response curves of the high-frequency loudspeakers obtained in the usual free-space testing condition. In Figs. 1 and 2, for example, the characteristic falls away above 2000 c/s., while Fig. 4 is the frequency characteristic of an identical loudspeaker obtained under test conditions. Early in the investigation the frequency response characteristics in the cinema were modified until a substantially level acoustic output was obtained to between 5,000 and 5,500 c/s. The aural results were considered unacceptable by the whole of the listening group, and after repeated tests the response characteristics represented in Figs. 1 and 2 were found to give the best aural results. Similar listening tests have been carried out in America, with the result shown in Fig. 5. The method employed in getting this characteristic was generally the same as that outlined above, modification being made to the equipment until the aural results met the approval of a listening group. In comparing Fig. 5 with Figs. 1 and 2 it should be remembered that the optimum frequency characteristic will depend to some extent on the reverberation-time / frequency curve. This information is not given for the American cinemas, and may explain the slight difference in the shape of the curves.

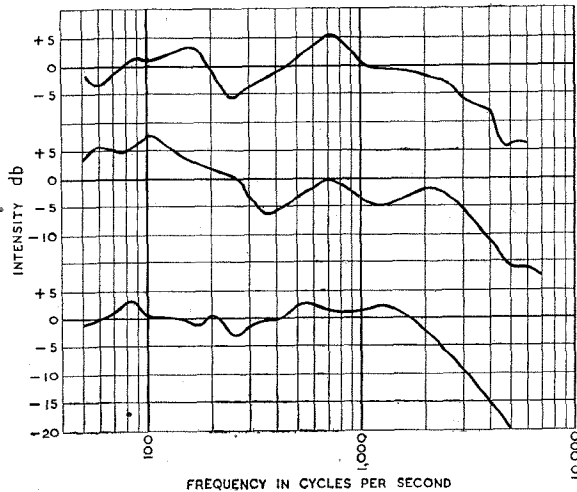

Fig. 3. Typical frequency characteristics for three Hollywood theatres.

the screen may be appreciated and followed by the audience.

Extremes in each district were chosen for further tests to ensure that known factors were not primarily responsible for the observed differences. Frequency characteristic and reverberation time were measured at many points in each theatre and the results compared. Results obtained in three typical theatres will serve to indicate the nature of the problem.

In theatre No. 1 sound was excellent throughout, and had received very favourable comments from many quarters. Theatre No. 2 was generally below average, while in theatre No. 3 sound was generally very good, but at certain points was poor.

**Frequency Characteristics**

Typical frequency characteristics taken in the three theatres are shown in Fig. 1, while Fig. 2 contains more detailed data on the frequency characteristic at four typical points in theatre No. 3. Curves (a) and (b) in Fig. 2 were recorded at points where the sound quality was considered to be above average, and curves (c) and (d) at points where the sound quality was below average.

Consideration of these results made it evident that there is no significant difference in the frequency response between the good and bad halls of theatres Nos. 1 and 2 (Fig. 1) or between

of the measuring apparatus without revealing any fault. The accuracy of the technique was further confirmed by the results obtained in three leading Hollywood theatres by American investigators.<sup>1</sup> These are shown in Fig. 3, and it is apparent that

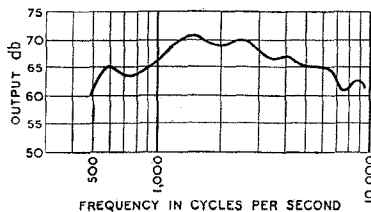

Fig. 4. Axial frequency response of HF speaker used in theatres of Figs. 1 and 2.

the frequency characteristics are comparable with those in Figs. 1 and 2.

It is of interest to observe that

<sup>1</sup> F. Durst and E. J. Shortt: *Journal of the Society of Motion Picture Engineers*, 1939, 32, p. 169.

Fig. 5. Overall frequency characteristic (adjusted for best aural results) published by American investigators.

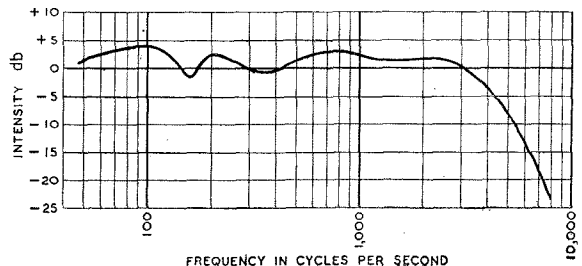

**Reverberation Time**

The results in the three cinemas are representative of the results in many cinemas investigated, and have led to the conclusion that either frequency response is not the major factor or that the measured frequency characteristic does not represent the characteristic to which the ear responds. Attention was therefore directed towards the acoustic properties of the halls and later to a study of

**Cinema Sound Quality—**

methods of instantaneous sound measurements.

Reverberation time is defined as the time taken for a diffuse sound field to be attenuated by 60 db., and is obviously a function of the

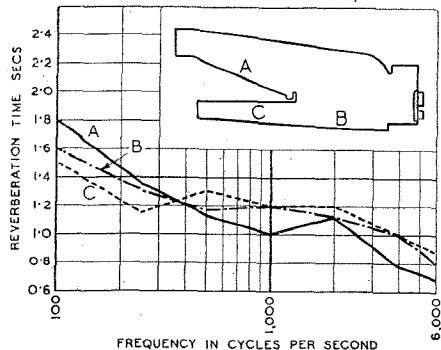

(Above) Fig. 6. Reverberation time at three positions in a theatre with balcony.

(Right) Fig. 7. Reverberation-time/frequency characteristics for theatres No. 1 and No. 2 of Fig. 1.

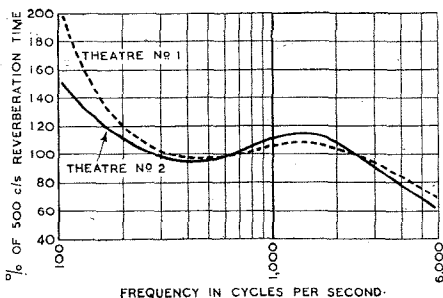

the similar characteristics for the four positions in theatre No. 3. Here again the differences are not sufficient to account for the differences in the aural result.

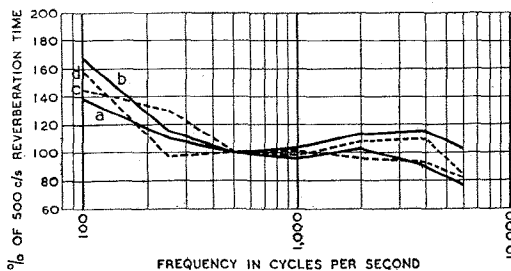

(Above) Fig. 8. Reverberation-time/frequency characteristics for the four positions in theatre No. 3 (see Fig. 2).

(Right) Fig. 9. Optimum reverberation time in relation to theatre volume.

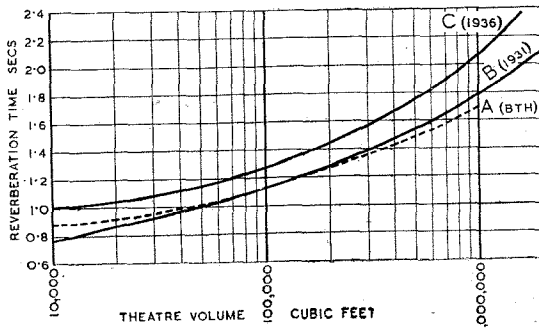

Considerable data have already been published on the optimum reverberation time as a function of theatre volume and frequency. This information is the result of several theoretical studies and field experience. Fig. 9 represents the author's optimum time/volume relation together with the recommendation of another large organisation,<sup>2</sup> curve B being the 1931 figures and curve C published in 1936, presumably the result of further field experience. An average curve is repeated in Fig. 10, and added to this are the 500 c/s reverberation times of several good and bad theatres. No consistent differences are apparent.

In passing it is of interest to note that on certain assumptions<sup>3</sup> it is possible to derive the optimum shape of the reverberation-time/frequency curve, and while the calculated curve is in general agreement with the measured results in theatre No. 2 below 500 c/s it departs widely at higher frequencies where, according to the calculated curve, the reverberation time should increase to approximately 150 per cent. at 4,000 c/s. The suggested rise in the theoretical curve has little support in the author's or other investigators' practical experience, which agree in requiring that the reverberation time should decrease steadily above 3,000 c/s.

For obvious reasons the measured times apply to the theatre's empty con-

<sup>2</sup> W. A. MacNair: *Journal of the Acoustical Society of America*, 1930, 1, p. 242.

S. K. Wolf and C. C. Potwin: *Journal of the Society of Motion Picture Engineers*, 1936, 27, p. 386.

<sup>3</sup> V. O. Knudsen: "Architectural Acoustics" (John Wiley & Sons, New York).

sound-absorbing property of the interior surfaces of the auditorium. In a uniform rectangular enclosure there is little doubt that a single value represents the reverberation time for the enclosure, but in a hall with a balcony (see, for example, Fig. 6) there is reason to doubt whether a single rate of decay exists for the complete enclosure, or whether it might not be more accurate to consider the enclosure as three separate spaces coupled by the balcony openings. Check tests were made in a typical theatre, and the results shown in Fig. 6 suggested that the variations are not sufficient to justify consideration as three separate coupled spaces.

Table 1 gives the reverberation

TABLE 1

Theatre	Measured	Optimum	Sound Quality
No. 1 ....	1.29	1.38	Above average
No. 2 ....	1.2	1.4	Below average
No. 3 ...	1.13	1.3	Average

Location	500 c/s Reverberation Time	Sound Quality
(a) ...	1.11	Above average
(b) ...	1.21	Above average
(c) ...	1.14	Below average
(d) ...	1.11	Below average

dition, although the suggested optimum figures are intended to hold with approximately two-thirds of the audience present. It is known that the presence of an audience modifies the acoustic condition, generally leading to improved sound quality if any effect is at

theatres with about two-thirds of the audience present have reverberation times far below the generally assumed figures. The effect, however, is common to all theatres, and cannot contribute to an explanation of observed differences between similar cinemas.

frequency modulation. My opinion is that the requirements can best be met by medium-carrier wave broadcast for national coverage, and by ultra-short-wave regional distribution for the densely populated centres."

In this inaugural address as Chairman, Mr. Goldup ranged over many other wireless topics; he presented a brief but highly informative historical review of valve manufacture, surveyed developments in broadcast and television technique, and detailed the progress made in radio communications. Leaving technical topics, he then went on to survey the organisation of the broadcast industry through the various trade organisations. His views on the transmission standards desirable for our post-war television service are commented upon editorially in this issue.

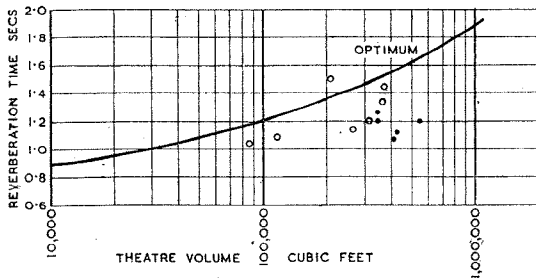

(Above) Fig. 10. Reverberation times of some good theatres (black dots) and bad theatres (circles) in relation to the optimum reverberation time curve.

(Right) Fig. 11. Reverberation time in a small auditorium (a) empty, (b) with full audience.

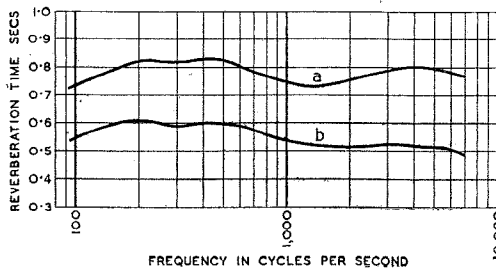

all noticeable. Knowing the reverberation time of the empty theatre it becomes an easy matter to recalculate the probable time with the audience present, but, as a check, the effect of an audience in a small theatre was measured, the data being presented in Fig. 11.

It becomes obvious that modern

criteria, judged by the subjective assessment of sound quality in large auditoria, unless they depart very widely from optimum conditions. Of much greater importance is the path or paths taken by the sound reaching the listener and this aspect will be dealt with in the next instalment.

(To be concluded.)

## BROADCAST DISTRIBUTION

### Economics of Wire and Wireless

**S**PEAKING before the Wireless Section of the Institution of Electrical Engineers, on Oct. 13th, T. E. Goldup, the new Chairman of the Section, touching upon some of the problems of broadcast distribution, referred to the vexed question of "wire versus wireless." He said: "... wire distribution of the modulated carrier frequency would have the advantage that several channels could be accommodated using one cable, but highly skilled work would be necessary to connect listeners to this system, and complete coverage in outlying districts would be impracticable.

"The programme coverage of the whole country by the present means

in the medium-wave band, whilst an economic proposition, has some disadvantages, such as liability to interference and fading, but these are problems capable of being overcome to a very great extent in practice; in fact, it would appear that none of the wire systems can compete with medium-wave carrier broadcasting, either economically or from the point of view of coverage. High-quality reproduction, low noise level and freedom from interference can be obtained in the wired system, but at an increased cost. These technical advantages are also obtainable by the use of ultra-short-wave regional distribution systems, possibly employing

## BOOK REVIEW

**Automatic Record Changers and Recorders.** By John F. Rider. Pp. 732. Published by J. F. Rider Publishing Co., 404, Fourth Avenue, N.Y., U.S.A. Price 6 dollars. (Obtainable in this country at 38s. from H. K. Lewis, 136, Gower Street, London, W.C.1.)

Although originally compiled, about two years ago, by the prolific Mr. Rider as an encyclopedia of American types of automatic gramophone record changer, among the full service instructions given in this big quarto-paged volume, copiously illustrated with explanatory diagrams and photographs, are included data on various equivalent types to the British, e.g., Garrard RC4, RC5 series.

The first four chapters deal with (1) motors and their maintenance, (2) so-called "home recording" and play-back equipment (of considerable interest to direct disc recordists are the complete circuits of certain American recording units, e.g., Presto, Fairchild, R.C.A.), (3) descriptions of the four basic types of auto-changer, i.e., the "drop," the "throw-off or ejector," the "turn-over," and the "two-side non turn-over," (4) a step-by-step analysis of the R.C.A. 152-C record changer, to enable any type of record changer to be dissected and its functioning understood.

The following major portion of this book, which can be recommended to anyone for whom the subject has a special appeal, is devoted to the manufacturers' service information, closing with a comprehensive index. D. W. A.

(Another book is reviewed on page 331.)



# RADIO DATA CHARTS—12

## Inductance, Capacity and Frequency : Short Wave

By

J. McG. SOWERBY,

B.A., Grad I.E.E.

(By permission of the Ministry of Supply)

**T**HIS chart and the two that will follow deal with the resonant frequency of tuned circuits in different ranges of the radio spectrum. The charts themselves present no difficulty in use and require very little explanation, so it is proposed to recapitulate some of the more important aspects of the underlying theory together with some practical details and notes on the use of the charts. It will be found that details most apposite to one particular chart may not appear with it but with one of the others; the three charts and their notes should therefore be considered as one article.

**Fundamentals**—To a very large extent the science (or possibly art) of radio depends on the ability to receive desired signals to the exclusion of others, and this is normally carried out with tuned circuits. In fact it would not be too much to say that the tuned circuit is the basis of wireless. There could be (and once were) receivers without valves, but a receiver without a tuned circuit would be a most unmanageable affair in these days of the crowded ether.

A tuned circuit is a network presenting a rapid change of impedance with frequency having a maximum or minimum at one unique frequency. By the judicious use of such networks signals of this one unique frequency can be separated from signals of all other frequencies, and so we have a device capable of selecting desired or rejecting undesired signals.

There are two basic tuned circuits—the *series* and the *parallel* combinations of capacitance and inductance. Since the inductance will normally consist of a coil of wire (under special conditions it can be a valve) it will necessarily have some resistance. The condenser too will inevitably have some losses which may be regarded as an equivalent series or shunt resistance, and these losses will be contributed by the energy lost in the dielectric used for in-

ducting the electrodes of the condenser. Fortunately condenser losses can be made very small even at high frequencies by using air as dielectric, as in parallel plate or concentric cylinder types, the plates being fixed by the minimum of solid dielectric which should be of quartz, ceramic material, polystyrene or other low-loss plastic. Thus it is usual (though not invariably entirely justified) to regard the losses as appearing in the inductive arm alone.

### The Series Tuned Circuit.—

The simpler of the two tuned circuits is the series or acceptor circuit shown in Fig. 1. The impedance between the two terminals may be written

$$Z = r + jX_L - jX_C$$

Where  $X_L$  &  $X_C$  are the reactances of L and C respectively and  $r$  is the resistance of the coil.

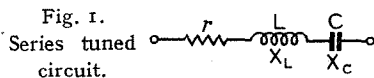

The absolute value (or modulus) of the impedance may be written

$$|Z| = \sqrt{r^2 + (\omega L - 1/\omega C)^2} \quad \dots \quad (1)$$

It is obvious from a glance at this equation that the minimum impedance occurs when the expression in the brackets is nothing (since it can never be negative); i.e. when  $\omega L = 1/\omega C$ , and so  $\omega^2 = 1/LC$  or since  $\omega = 2\pi f$ ,

$$f = \frac{1}{2\pi\sqrt{LC}} \quad \dots \quad (2)$$

At this frequency, then, the imaginary term of (1) disappears and the impedance, falling to a minimum, becomes simply the resistance  $r$ . The frequency given by (2) is called the resonant frequency and this is the formula which everyone knows.

Having found the resonant

frequency it will now be interesting to calculate the currents and voltages in the circuit. By Ohm's law, the current in the circuit must be  $I = E/Z$  where  $I =$  current and  $E =$  applied voltage; and the current must, by Kirchhoff's laws, be the same at all points in the circuit. But at resonance  $I = E/r$ . Now the resistance of a coil can be made quite low compared to its reactance at radio (or even audio) frequency, so at resonance the current will be very much higher than at any other frequency. But the current passes through L and C and so the voltage across either of them must be the product of the current and the appropriate reactance.\* In addition, the two reactances are equal at the resonant frequency, hence the voltages across them will be equal. We may write the voltage ( $E_R$ ) across one of them as

$$E_R = E\omega L/r = E/r\omega C \quad \dots \quad (3)$$

The factor  $\omega L/r$  is known as the Q of the coil and the voltage across the coil is seen to be the voltage (E) applied to the whole circuit multiplied by this factor. A coil of  $Q = 50$  is by no means unusual and in a series circuit such a coil would produce across its terminals a voltage 50 times as great as the applied voltage. For this reason the Q of a coil is sometimes referred to as its magnification, but it truly magnifies the voltage only in the case of the series tuned circuit, and the meaning of the term would not be immediately obvious from consideration of the parallel tuned circuit alone—though it is clear enough from the above. It may perhaps be wondered where the voltage across the coil or condenser "goes to" when the circuit is considered as a whole. The explanation is quite simple, however, as the voltages across the coil and condenser are out of

\* This is not strictly accurate except when  $r = 0$  since the voltage across  $r$  cannot in practice be separated from the voltage across L. For practical purposes, however, no serious error is introduced.



ABAC No. 12  
[Third Series]

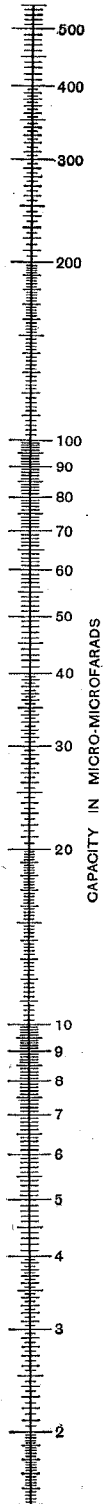
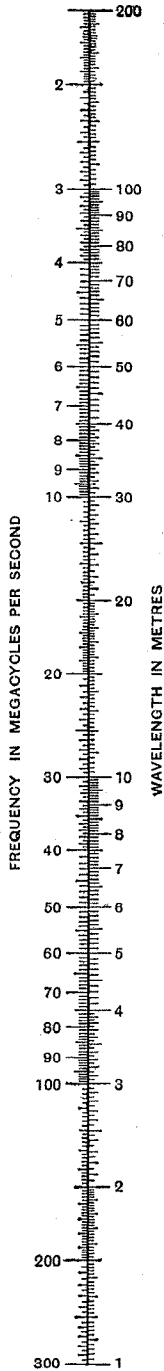
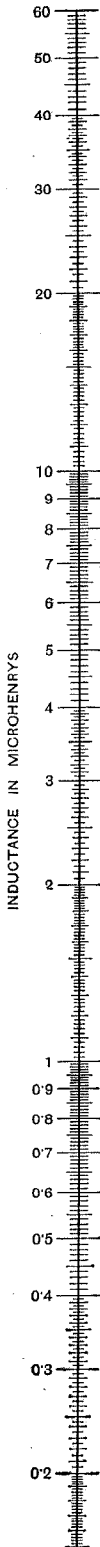

INDUCTANCE CAPACITY AND FREQUENCY  
SHORT WAVE

Wireless World  
COPYRIGHT

**Radio Data Charts—**

phase with one another and so cancel out leaving only the voltage drop across  $r$  which is, of course, the applied voltage  $E$ .

**Practice**—The series resonant circuit is used for a number of purposes—usually for filtering out unwanted signals of a specific frequency. It might be used, for instance (though better circuits could be designed), for removing the 9 kc/s heterodyne between stations in receivers of large bandwidth. However, it is the parallel

tuned circuit (Fig. 2) which is most used in radio receivers and the theory will be dealt with later. For most practical purposes it may be taken that the resonant

**Fig. 2.**  
**Parallel resonant circuit.**

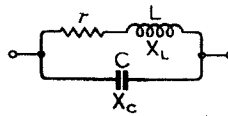

frequency of this circuit is given by  $f = 1/2\pi\sqrt{LC}$  which is the same as for series resonance, and the chart is based on this formula since it is simple and both

series and parallel circuits can be calculated with it.

**The Chart.**—The chart needs no key, being very simple in operation; it is only necessary to connect two of the quantities  $f$ ,  $L$ , and  $C$  together with a ruler when the third will appear opposite the ruler on the appropriate scale. The procedure is rapid and is well adapted to making numerous determinations.

**Example.**—To what frequency do  $4\mu\text{H}$  and  $12\mu\mu\text{F}$  resonate?  
Ans. 22.97 Mc/s (13.06 metres).

**NEWS IN ENGLISH FROM ABROAD**

Country : Station	Mc/s	Metres	Daily Bulletins (BST)	Country : Station	Mc/s	Metres	Daily Bulletins (BST)
<b>Algeria</b>				<b>India (continued)</b>			
Algiers .. .. .	8.965	33.46	1600, 1700, 1800, 2100, 2200	VUD4 .. .. .	9.590	31.28	0800, 1300, 1550
	12.110	24.77	1700, 1800, 2100	VUD3 .. .. .	15.290	19.62	0800, 1300
<b>America</b>				<b>Mozambique</b>			
WRUW (Boston) ..	6.040	49.67	0800	CR7BE (Lourenco Marques) ..	9.830	30.52	1155, 1712, 1915
WLWO (Cincinnati) ..	6.080	49.34	0800				
WCBX (Brentwood) ..	6.170	48.62	0500	<b>Newfoundland</b>			
WGEO (Scheneectady)	6.190	48.47	0515	VONH (St. John's) ..	5.970	50.25	2315
WKTM .. .. .	6.370	47.10	0200, 0300, 0400, 0500, 0600, 0700, 0800, 0900	<b>Palestine</b>			
				Jerusalem .. .. .	11.750	25.53	1615
WLWK (Cincinnati) ..	7.575	39.60	0600, 0700, 0800, 0900	<b>Portugal</b>			
WCRC (Brentwood) ..	9.650	31.09	0600	CSW6 (Lisbon) ..	11.040	27.17	2000
WLWO (Cincinnati) ..	11.710	25.60	1100, 1200, 1300, 2100, 2200	<b>Spain</b>			
				EAQ (Aranjuez) ..	9.860	30.43	1815‡
WCRC (Brentwood) ..	11.830	25.36	1100, 1200, 2200	<b>Sweden</b>			
WGEO (Scheneectady)	11.847	25.33	1300, 1400, 1500, 1600, 1700, 2300	SBU (Motala) ..	9.535	31.46	2220‡
				SBP .. .. .	11.705	25.63	1700
WBOS (Hull) .. ..	11.870	25.27	1200	<b>Switzerland</b>			
WKTM .. .. .	11.893	25.22	0000, 2300	HER3 (Schwarzenburg)	6.165	48.66	2150
WKRD .. .. .	12.967	23.14	0000, 1300, 1400, 1500	HER4 .. .. .	9.535	31.46	2150
WBOS (Hull) .. ..	15.210	19.72	2100	<b>Syria</b>			
WLWK (Cincinnati) ..	15.250	19.67	1400, 1500, 1600, 1700, 1800, 1900, 2000, 2100, 2200	Beirut .. .. .	8.035	37.34	1820
				<b>Turkey</b>			
WGEO (Scheneectady)	15.330	19.57	1100, 1200, 2200	TAP (Ankara) ..	9.465	31.70	1800
WRUL (Boston) ..	15.350	19.54	1500, 1600	<b>U.S.S.R.</b>			
WLWO (Cincinnati) ..	17.800	16.85	1500, 1600, 1700, 1800, 1900, 2000	Moscow .. .. .	5.890	50.93	2300
					6.980	42.98	1240, 1700, 2300
<b>Australia</b>					7.300	41.10	1800, 2000, 2100, 2200, 2300
VLI10 (Sydney) ..	9.580	31.32	1515		7.560	39.68	2300
VLG3 (Melbourne) ..	11.710	25.62	0800		10.445	28.72	1240
VLI2 (Sydney) ..	11.872	25.27	0800		11.830	25.36	1600
VLG9 (Melbourne) ..	11.900	25.21	1515		12.190	24.61	1240
VLI3 (Sydney) ..	15.320	19.58	1030		15.230	19.70	0415, 1240
					15.750	19.05	1240
<b>Brazil</b>				<b>Vatican City</b>			
PRL8 (Rio de Janeiro)	11.715	25.61	2030‡	HVJ .. .. .	5.970	50.25	2015
<b>China</b>							
XGOY (Chungking) ..	9.635	31.14	1500, 1700, 2130	<b>Algeria</b>			
				Algiers .. .. .	1176	255	0100, 1400, 1800, 1900, 2000, 2200
<b>Ecuador</b>				<b>Athlone</b> .. .. .	565	531	1340‡, 1845, 2210
HCJB (Quito) ..	12.455	24.09	0000, 2030	<b>Tunis</b> .. .. .	868	345.6	0000, 0100, 2000, 2100, 2200, 2300
<b>Egypt</b>							
Cairo .. .. .	7.510	39.94	1840, 2100				
<b>French Equatorial Africa</b>							
FZI (Brazzaville) ..	11.970	25.06	1945, 2145				
<b>India</b>							
VUD3 (Delhi) ..	7.290	41.15	0800, 1300, 1550				

It should be noted that the times are BST—**one hour** ahead of GMT. The timing of some of the bulletins may be changed to compensate for the reversion from Summer to Standard Time in some countries. ‡ Sundays excepted.

# ELECTRONIC VOLTAGE REGULATORS

## Simplified Method of Design : Estimation of Performance

AN electronic voltage regulator is a most useful device, particularly for test gear and such apparatus where mains voltage fluctuations are troublesome. Many types are known, but it is proposed in this article to concentrate on one particular circuit and some modifications to it; to show how a suitable regulator can be designed in a simple manner. The circuit is the one which I consider to be most universally applicable to radio work.

Much has been published on the subject, particularly in the literature of physics, but with few

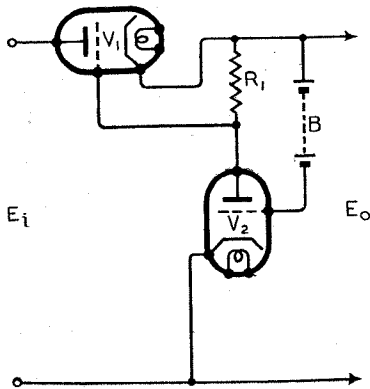

Fig. 1. Basic circuit of type of voltage regulator discussed in this article.

exceptions these articles describe particular stabilisers and give details of their performances, good, bad and indifferent, which is of little help to busy engineers. The formulae which have been published are, in general, inapplicable without considerable information on the valves to be used, in such a way that direct measurements are usually necessary. Other writers emphasise the methods of designing the power unit, and gloss over the actual electronic stabiliser. I may have been unfortunate, but the many articles I have read in the past years on the subject all fall to a greater or lesser extent under these strictures. The reason is not far to seek, to my mind. It is that in practice there is no alternative to "hit and miss," and a good deal of intelli-

By F. LIVINGSTON HOGG

gent guessing. I am therefore describing in detail the method of controlling the guesswork which I have evolved for my own use, which has served well for some years, and has helped to design regulators which are not based on unsound operating conditions. The method is empirical, and can usually be completed on paper from makers' catalogues and figures with a reasonable hope of obtaining the desired results.

The basic circuit is shown in Fig. 1. The input from a rectifier or other source is passed to the load through a valve  $V_1$ . This valve obtains its bias from the anode current of  $V_2$  through  $R_1$ . The anode current of  $V_2$  is controlled by the battery B. It is clear that if the input voltage rises, the output voltage tends to rise. This causes the grid of  $V_2$  to become more positive, which increases the anode current through  $R_1$ . This biases  $V_1$  more negatively, and hence reduces the variation of output voltage by an amount depending on the amplification of the circuit  $V_2$ ,  $R_1$ , and the slope of  $V_1$ , among other things. Obviously the battery B has to be of slightly higher voltage than the required output, which is very inconvenient, although other more economical arrangements are possible.

For all normal purposes we can, fortunately, use a gas-filled stabiliser tube instead of the battery B, by rearranging the circuit as shown in Fig. 2 (a).  $N_1$  holds the cathode of  $V_4$  at a definite voltage above earth.  $P_1$  is adjusted so that the voltage on the grid of  $V_4$  is the required amount below the voltage on its cathode.

Now let us go through the circuit and consider its limitations and design requirements. First of all, we need to know the performance of the rectifier or other source, i.e. its regulation and range of variation with mains voltage, etc. Then we can see that  $V_3$  will have to pass a little more than the full load current, and also, if it is to regulate, it must be biased negatively. This means that the voltage drop across it may be considerable. The minimum figure is likely to be about 100 volts in an average case.  $V_4$  is a straightforward resistance-coupled amplifier, and therefore its performance is dependent on the anode voltage available, the valve, and the resistance  $R_2$ .  $N_1$  may drop from 55 to 150 volts according to the type of tube used. This means that there is a limit to the lowest output voltage available, as that voltage must be the sum of the voltages across  $R_2$ ,  $V_4$  and  $N_1$ . In general this drop cannot easily be much less than 65 volts plus the drop across  $N_1$ , or about 120 volts. The current in  $N_1$  may

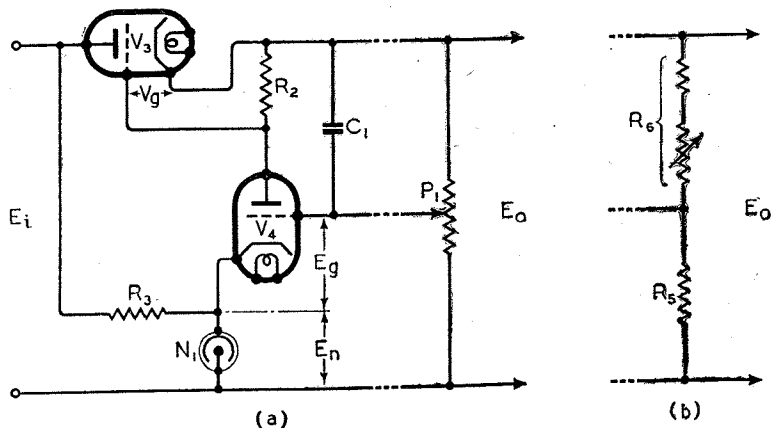

Fig. 2. (a) Circuit arrangement using a neon lamp instead of the battery in Fig. 1. (b) Practical arrangement of potentiometer  $P_1$ .

### Electronic Voltage Regulators—

be restricted by makers rating to a range which is above the working current of  $V_4$ . In this event a shunt resistance  $R_3$  from the HT input line to the cathode of  $V_4$  will enable the current to be brought up to a suitable amount.

Some users of these circuits complain that they require adjustment very frequently, and that they are not inherently very stable, unless batteries are used in place of the gas discharge tube. In using such devices I have found a good many unstable and variable ones, but the trouble has always been due either to amplifier instability, i.e. tendency to oscillate, or to the potentiometer  $P_1$ . This latter is often made high, from 100,000 ohms to 2 megohms. Now the grid of  $V_4$  is not supposed to take current, neglecting leakage, etc. What happens is that, although the total resistance of  $P_1$  remains constant, the tapping point appears to vary from time to time, usually taking up a different value each time the apparatus is switched on. This is not surprising, considering the absence of current through the tapping point; and when the voltage across the resistance is of the order of maybe a hundred volts or more, it is obvious that a minute variation in resistance will produce a noticeable variation

in bias on  $V_4$ . It is interesting to work out the degree of constancy required for  $P_1$  for a given case. After that, the maker of the potentiometer will no longer be blamed! A better device than the potentiometer is a combination of fixed and variable resistances, as shown in Fig. 2 (b). In any case, the variable resistance should be wirewound.

The design may now be started. Let us assume some values for an example:—

Output voltage  $E_o$  to vary from 350 to 190 volts, continuously.

Output current  $I_o$  to vary from 75 to 10 mA, independently.

Mains input to rectifier varies  $\pm 8$  per cent.

Regulation of rectifier from 10 to 75 mA, 10 per cent.

Stabiliser tube working voltage 55. (S.T.C. type 4313C.)

The next step is to make a table. Columns are lettered and rows numbered so that any square may be identified. Columns A and B are filled in thus: Rows 1, 2 and 3 are filled in with  $E_o$  max and  $I_o$  max in each case. Rows 4, 5 and 6 have  $E_o$  max  $I_o$  min. Rows 7, 8 and 9 have  $E_o$  min  $I_o$  max, and finally the remaining rows  $E_o$  min  $I_o$  min. Each row in the four sets is for normal, maximum and minimum rectifier output voltages ( $E_i$ , column C). Assume a safe value of 150 volts

for the drop across  $V_3$  in row 1, column D. Obviously C.1 is then 500 volts. C.2 and C.3 are therefore plus and minus 8 per cent. on this figure. C.7, C.8 and C.9 correspond to C.1, C.2 and C.3; the remaining rows have a further 10 per cent. added for the rise due to the regulation, as the current is low. We can now fill in the rest of D,  $E_i-E_o$ , whence column E, watts dissipation in  $V_3$ . Having completed the table thus far, we must find a suitable valve for  $V_3$ . A DO24 or PX25 triode suits excellently. But, as we know the anode current and voltage of this valve, we can read off the necessary bias from the maker's anode current/anode voltage curves, which gives column F.

$R_2$  must now be chosen. In general it will not be found advantageous to use a higher value than 0.1 or 0.2 megohm. Although the stage gain rises as  $R_2$  is increased we have a fixed volt drop across  $R_2$ . The decrease in anode current which follows means reduced slope in the valve, so that a compromise must be made. In this example 0.2 megohm will be assumed. The voltage across  $R_2$  is given in F, so that we can at once complete G, the current through  $R_2$ . We must now choose  $V_4$ . Let us take a 6Q7G, a high-mu triode. Column H shows the voltage across this valve, found

	A	B	C	D	E	F	G	H	I	J	K	L	M	N
	$E_o$ (volts)	$I_o$ (mA)	$E_i$ (volts)	$V_3$ Volt drop	$V_3$ Watts	$V_3$ Bias volts	Current in $R_2$ (0.2 meg- ohm) (micro- amps)	$V_4$ Anode volts	$V_4$ Bias volts	$R_2$ (ohms)	Effective output variation (volts)	Current in $R_2$ (0.5 meg- ohm) (micro amps)	$V_4$ Bias volts	Effective output variation (volts)
	Using stabilizer tube (Fig. 3)													
1	350	75	500	150	11.3	-6	30	289	Bias -5.5	53600	—	122	Bias -4.9	—
2	350	75	540	190	14.3	-11	55	285	+0.27		+1.7	132	+0.1	+0.64
3	350	75	460	110	8.3	-1	10	293	-0.27		-1.7	114	-0.1	-0.64
4	350	10	550	200	2	-23	115	272	+0.75		+4.8	156	+0.44	+2.8
5	350	10	605	255	2.6	-30	150	265	+1.01		+6.4	170	+0.6	+3.8
6	350	10	495	145	1.5	-16	80	279	+0.48		+3	142	+0.3	+1.9
7	190	75	500	310	23.3	-27	135	108	Bias -2.2	24500	—	164	Bias -2.1	—
8	190	75	540	250	26.3	-32	160	103	+0.13		+0.45	174	+0.1	+0.35
9	190	75	460	270	20.3	-22	110	113	-0.13		-0.45	154	-0.1	-0.35
10	190	10	550	360	3.6	-44	220	91	+0.42		+1.4	198	+0.33	+1.2
11	190	10	605	415	4.2	-51	255	84	+0.58		+2	212	+0.46	+1.6
12	190	10	495	315	3.1	-37	185	98	+0.26		+0.9	184	+0.2	+0.69



by subtracting from A the stabiliser tube drop, 55 volts, plus F. From the maker's curves we can then get the corresponding bias for the given anode voltage and current in  $V_4$ , which we fill in I. As high values of  $R_2$  are used, however, it may be difficult to read the curves closely enough. To get over this difficulty we fill in I.1 and I.7, and then enter in the rest of I the changes in bias which have to be made.

The maker's anode current/anode voltage curve helps us here. The amplification factor of the valve is near enough a constant. By means of this fact, and a little careful interpolation, all the necessary information can be obtained. If we read off the corresponding anode voltages at the required current for two adjacent bias curves we can interpolate to find the bias corresponding to the known anode voltage.

**The Potential Divider**

The next step is to evaluate  $R_5$  and  $R_6$  in Fig. 2 (b), which replace  $P_1$ . A convenient value for  $R_5$  would be 10,000 ohms. This will result in a constant bleed current of about 5 mA. The relationship between the resistances is:

$$\frac{R_6}{R_5} = \frac{E_o - E_n + E_g}{E_n - E_g}$$

As  $E_g$  is so small we may approximate:

$$R_6 = R_5 \left( \frac{E_o}{E_n} - 1 \right)$$

We then get two extreme values for  $R_6$  corresponding to the maximum and minimum values of  $E_o = 53,600$  and  $24,500$  ohms. It is worth while to split  $R_6$  into a fixed portion and a variable, so that it cannot be reduced below 24,500 ohms. These values should be built up on test, so that the correct operating range is covered and no more, otherwise the regulator may be unjustifiably blamed for failure. In this case a variable of 50,000 ohms would be suitable. On test the value of 24,500 ohms should be built up until the lowest allowable output is attainable on minimum current and maximum mains volts, the variable being at minimum. The variable can then be shunted by a fixed resistance of the order of 75,000 ohms, so that at maximum variable resistance the maximum voltage and current output are

obtained on low mains volts. This adjustment takes about as long to do as to describe, and is a good safeguard in exchange for a couple of extra fixed resistances. In what follows, the built-up values of  $R_6$  are treated as single resistances.

The potential divider formed by  $R_5$  and  $R_6$  reduces the efficiency of the regulator by a factor:

$$\frac{R_5}{R_5 + R_6}$$

Remembering this, the performance of the whole may be tabulated in column K. K.1 and K.7 are reference points, the others are found thus: K.2. is given by:  $(R_5 + R_6)/R_5$  times the bias difference I.2, and so on.

This is the actual change of output voltage, which we have saved ourselves much difficulty by assuming absent. Fortunately, this is quite near enough for practical purposes. We have now completed the design of the circuit shown in Fig. 2 (a) and (b).

A glance at the table shows that there are three lines only which are of major importance. These are:

(1.) Line 3, when  $E_i$  is a minimum, and  $E_o$  and  $I_o$  are both at maximum. In this case the bias on  $V_3$  is a minimum, and must obviously be kept to  $-1$  volt or even more.

(2.) Line 8, when  $E_i$  and  $I_o$  are maximum, and  $E_o$  minimum.

(3.) Line 11, when  $E_i$  is a maximum and  $E_o$  and  $I_o$  are both at minimum. In this case the anode voltage on  $V_4$  is at its lowest, and the corresponding anode current is at maximum. The limit is the lowest desirable bias on  $V_4$ , which may be  $-\frac{3}{4}$  volt.

If we are sure that  $V_3$  and  $V_4$  are being arranged to work efficiently, and are going to have the right order of voltages on them, these three lines are all that need be worked out for a new design, but until all pitfalls are understood, it is better to work out the complete table, and to study the effect of the various obvious changes of values which would be made.

This worked example is a very inefficient regulator, but it has been deliberately chosen so that the principles of operation may be clearly understood. A considerable improvement would be obtained by using say a Brimar 8D2 pentode in place of the 6Q7G, as is mentioned later. In more efficient regulators, the bias changes often become so small as to be difficult to estimate, and the experienced designer will merely ensure that  $V_4$  works at the maximum efficiency allowed by conditions, using the table only for  $V_3$ . When the necessary test gear is available, the overall amplification of this stage  $V_4$  may be measured at audio frequency

under the various working conditions, and the optimum values then chosen for a particular case. This is especially useful in the case of the screen voltage on a pentode, which sometimes prefers rather peculiar values.

Now even if we use the best possible arrangement of this circuit

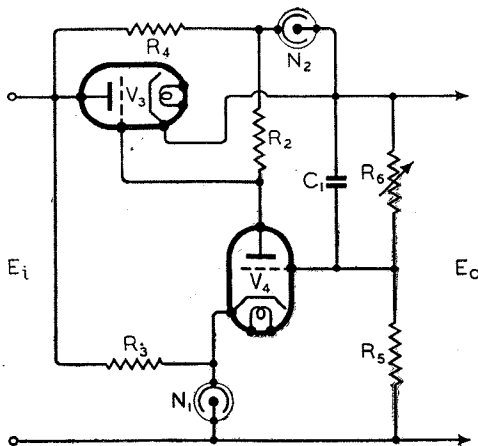

Fig. 3. Circuit designed to increase the efficiency of  $V_4$ .

This gives maximum watts dissipation on the anode of  $V_3$ . If valve manufacturers did not read *Wireless World*, I would admit that I usually allow a 10 per cent. margin over maker's rating, as the condition is not often a working one.

there is still a residual change, small though it may be. Let us consider how this can be improved. Obviously  $V_4$  cannot work under the best conditions, as typified by ordinary resistance-coupled amplifier technique, with a given anode resistance, because

**Electronic Voltage Regulators**—of the limited anode voltage, across the resistance, with correspondingly low anode current. The circuit of Fig. 3 shows a method of dealing with this. If we use the same anode resistance as before, the anode current will be increased greatly, or alternatively, the anode resistance may be raised for the same current.

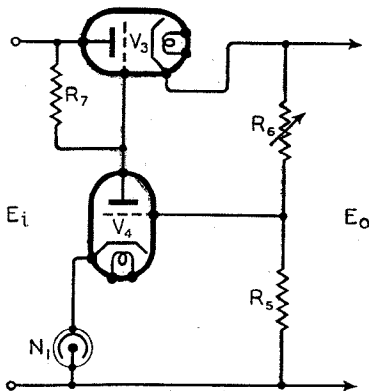

Fig. 4. Commonly used alternative circuit to that of Fig. 3 which is less efficient in practice.

Two components only are added,  $R_4$  and  $N_2$ .  $R_4$  is chosen to bring the tube current to a reasonable value. If a 4313C stabiliser tube is used, it might be about 50,000 ohms in our example. The voltage in D shows the range that the tube has to cover without exceeding the maximum current rating. The maximum current is about 7 mA, so that this requirement is met. At the other extreme the minimum current will be of the order of 1 mA—this is also in the regulating range of the tube. Now it is clear that the change to the circuit has increased the volt drop across  $R_2$  by the amount of the tube drop, 55 volts. We can now fill in columns L, M and N of our table. We take advantage of the increased voltage to raise  $R_2$  to 0.5 megohm. Then by comparing K and N we can see the improvement obtained by using this device. Note that the voltage across  $V_4$  is unaltered. To be accurate, the currents in  $V_3$  should be recalculated, allowing for the shunt circuit across it. This shows the efficiency to be less, particularly at low currents, than appears from N.

It is seen that despite the apparent advantages at first sight of this method, which has been

suggested by more than one writer, the actual improvement is slight, being greatest at the high-voltage, high-current end. In this case it is scarcely worth while to use the extra tube, but when the bias on  $V_3$  has a small range, close to zero bias, the method is valuable.

A method often proposed instead of the above, with the same end in view, is simply to connect  $R_2$  to the anode of  $V_3$  instead of to the cathode, Fig. 4. Unfortunately this circuit is not as good as it looks. As the bias on  $V_3$  varies, so does the volt drop across  $V_3$ . This volt drop across  $R_7$  varies in the same way, and in such a direction that it opposes regulation, i.e. it necessitates a correspondingly larger change in bias on  $V_4$ . The increase in amplification obtained by the higher possible value of  $R_7$  and the higher anode current to  $V_4$  is usually much more than offset by the opposing variations. In fact it can be shown that if the amplification of  $V_4$  is constant in the two cases, the stabilising effect is reduced by a factor equal approximately to the amplification factor of  $V_3$ . If  $V_4$  gives lower amplification, this must be allowed for in a comparison, but I have not met a case yet in practice where the balance was not in favour of the cathode connection.

It is necessary to point out here a disadvantage of the method of Fig. 3. First, stabilising tubes are not perfect, they have small spasmodic variations which may be of the order of a few tenths of a volt. Each additional tube therefore has its deleterious effect. Secondly, the changes in current in column L are much smaller

Fig. 5. Circuit with voltage and current compensation for fluctuations of input voltage and load.

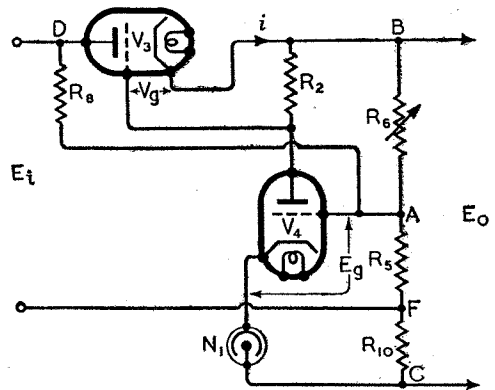

than in G. Thus any valve or circuit irregularities will show up far more in the former case. It is always as well to keep the anode current reasonably large, to minimise these spasmodic valve irregu-

larities. Failure to do so has sometimes caused complaints of unstable regulation.

Supposing we want still better regulation. There are two little-known devices we can use to improve matters. These were both described by Lindenhovius and Rinia in *Philips Technical Review*, Vol. 6, No. 2, 1941, which is not readily available in this country, and the principles involved will therefore be dealt with in detail. B. Banerjee, in the *Indian Journal of Physics*, Vol. 16, Pt. 2, 1942, also puts forward similar ideas, independently.

There are two kinds of output variation we have to consider variation caused by fluctuating input voltage, and that caused by fluctuating load. The methods to be described deal with these two cases.

Treating these points separately first, let us consider what must occur if the regulation were really perfect, as we assumed in our example. In Fig. 5 ignore for the moment  $R_{10}$ . It is clear that for constant output voltage with varying input voltage, we would have to produce a certain change in voltage at A, across  $R_6$ , related to the input variations. Now if we feed a small portion of the input voltage through  $R_8$  to A, the variation required will be obtained in the correct phase. In the table the first three lines show a change of input voltage of  $\pm 40$  volts. The corresponding change on the grid of  $V_4$  is approximately  $\pm 0.27$  volt. Then if  $R_5$  is 10,000

ohms and  $R_6$  53,600 ohms, the required value of  $R_8$  will be about  $1\frac{1}{4}$  megohms. ( $R_5$  and  $R_6$  are effectively in parallel, as if the regulation is perfect, the internal resistance as seen across the out-

put terminals is zero.) Of course a different value of  $R_8$  is required for each output voltage: for lines 7, 8 and 9 in the table it should be nearly  $2\frac{1}{2}$  megohms. In practice it is often possible to compromise; an intelligent guess is made at  $R_8$ , which is made variable, and a good compromise found by experimentally varying the input voltage and noting changes. The compromise value is then built up from a number of fixed resistances as may be required.

Here again we have made an assumption which must not be overlooked. Obviously the current through  $R_8$  will increase

Fig. 6. Compensated bridge circuit suggested by Lindenhovius and Rinia.

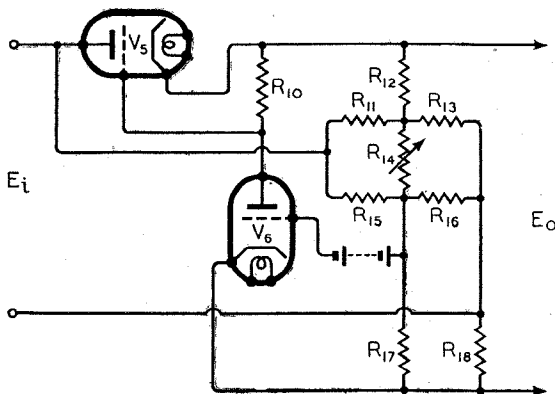

the volt drop across  $R_5$ . To keep the output voltage constant in the first case above,  $R_6$  would have to be increased to about 57,500 ohms. In practice this can usually be neglected.

The second case may be considered similarly, ignoring  $R_8$  in Fig. 5. If the output voltage is constant, variations in load cause changes in the load current. This means that corresponding changes must be applied to point A as above. This can be done by adding  $R_{10}$  and thus changing the position of  $R_5$ .  $R_{10}$  may be estimated as was  $R_8$ . A variable resistance of 100 ohms is good for experiment, and a compromise can usually be found which meets requirements. For the two voltages quoted, the values of  $R_{10}$  would be 15 and 8 ohms approx.

If both voltage and current compensation are used together, as shown in Fig. 5, rather lower values of  $R_{10}$  are required, as owing to the impedance of the rectifier circuit,  $E_i$  rises or falls as the current falls or rises. This reduces  $R_{10}$  above to 8 and 5 ohms. In other words, voltage compensation is a misnomer, for the first arrangement also gives a certain amount of current compensation.

These compensating devices

usually render the stabiliser tube device of Fig. 3 unnecessary, except when a large power valve or valves are to be used over a range which is always close to zero bias.

When compromise is made in the values of the compensating resistances, perfect compensation is obtained only at one voltage or current, with over-compensation taking place on one side, and under-compensation on the other

side. In practice, the approximately compensated circuit is almost invariably better at all points than the corresponding uncompensated one.

A further arrangement was suggested by Lindenhovius and

Rinia which, they claim, enables the two compensations to be made independent of variation of output voltage caused by the controls. The method involves the setting up of a rather complicated bridge network, but might be of great value when the highest precision is required. Using this arrangement with battery bias instead of a stabiliser tube, an output variation of less than 0.004 per cent. is claimed for a mains variation of 5 per cent. The circuit principle is shown in Fig. 6. The relationships of the network are given as:

$$\frac{R_{11}}{R_{12}} = \frac{R_{15}}{R_{17}} \div n\mu - 1$$

$$\text{and } \frac{R_{13}}{R_{12}} = \frac{R_{16}}{R_{17}} \div nSR_{18} - 1$$

where n = overall amplification of  $V_6$ .

S = mutual conductance of  $V_5$ .

$\mu$  = amplification factor of  $V_5$ .

$R_{14}$  is of suitable value to give the required output voltage variation. This circuit could obviously be adapted to use a stabiliser tube instead of a battery. I have not tried it, as all practical cases have so far been met with the other simpler circuits, but it is included for completeness, as it is not readily available elsewhere.

(To be concluded.)

## BOOK REVIEW

**The Technique of Radio Design.** By E. E. Zepler, Ph.D. Pp. 311 + XII; 260 figures. (Chapman & Hall, 11, Henrietta Street, London, W.C.2.) Price 21s.

DR. ZEPLER'S book should serve as an introduction to the "back-room" of receiver design, and provide the inexperienced engineer with the practical design data and methods of measurement and test which cannot be included in theoretical studies and are usually acquired only slowly by experience. The practical viewpoint of the author is emphasised by the use of formulæ in which the constants have been reduced to the simplest numerical form; for example, a textbook of electrical theory would give the capacitance of a parallel-plate condenser as  $A/4\pi d$  "absolute electrostatic units," but it is here given as  $A/11.3d$  pF., which is more to the point for practical applications. Most of the chapters are on general subjects, such as "The Amplifier Stage," "Selectivity," and "The Principles of Screening," but there is also "Problems of

Detection and Frequency-Changing," devoted to these particular stages of a receiver.

The only serious criticism is of a tendency for the author to write in terms of the high-class communications receiver and neglect the mass-produced broadcast receiver which formed 80 per cent. of the output of the pre-war British radio industry. For the latter, it is unfortunately not true that the average receiver has two stages of preselection, with a tendency to increase this to three stages (p. 145). This point may be regarded as merely bad design in the cheaper class of receiver, but the statement that with a flat AVC characteristic the manual AF gain control need only have a range of 1:3 (see p. 179) is surely not applicable to broadcast receivers of any type. Provided this tendency to concentrate on the communications receiver is realised, the book will give a good insight into the development of a new receiver design.

D. A. B.

(Another book is reviewed on page 323.)



# COMMANDO SIGNALS

## Wireless in a "Corps d'Elite"

**S**PEED of operation and the high mobility of the modern short-range wireless set make it an obvious means of communication for the type of warfare in which Commandos are engaged.

Although signals sections are a more or less recent addition to Commandos, they have played an important part in a great many

Signals for this hazardous, but far from humdrum, work. In addition to the badge of R. Signals on their green berets, they wear the Combined Operations badge, above which are the words "Commando Signals."

The function of Commando Signals is to provide all means of communication required by Commando troops on operations. This includes communications between landing parties, between landing parties and their headquarters and between troops ashore and ships and assault craft off-shore.

Each Commando (the term used for a unit which can be compared with a small, but highly offensive, battalion) has a signal section for communication between parties of its own men and back to its own landing craft. For providing communications between two Commandos or between Commandos and other troops taking part in a landing, there is a Special Service Brigade Signal Troop. It is not, however, proposed to deal with the work of this branch, but to confine ourselves to Commando Signals.

In addition to being a first-class operator, a Commando signaller must be a fully trained Commando soldier, for not only has

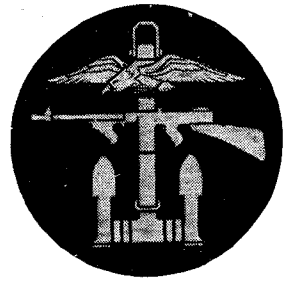

Combined Operations Command badge, embroidered in red on blue, worn on the upper arm of men of Commando Signals.

he to carry out his signal duties under the extremely difficult and often arduous conditions of Combined Operations, but also must be able—and equipped—to take a hand in fighting if the need arises. Great importance is attached to physical fitness and ability to march fast while carrying additional weight, as it is highly probable signallers will have to keep pace with Commando assault troops who are not encumbered with wireless gear. All equipment used by signallers must be capable of being carried by the operators; if necessary for some days.

Probably the best way of describing the work of Commando Signals is to give some details of an exercise in which *Wireless World* was privileged to take part. The "scheme" was an exercise in signals communications



Man-power! A Commando signaller, complete with No. 18 pack transmitter-receiver scaling a roof-t. cliff, which, incidentally, was much more nearly vertical than this photograph would suggest.

operations ranging from small raids on enemy or enemy-occupied coasts to the large-scale landings in Algeria, Tunis, Sicily and Italy. As the scale of operations becomes bigger and more complicated, it is certain Commando Signals will have an increasingly important part to play.

Most of the officers and men in Commando Signals have volunteered from the Royal Corps of

Hauling equipment up the cliff. This piece of apparatus is the No. 21 set complete with aerial in carrying case.





involved in the landing on one beach of two parties, each of which was attacking different objectives some two miles inland. It is perhaps noteworthy that the majority of the men taking part in the exercise had been on actual operations.

The two forces (Red and Blue) taking part took to the boats from the headquarters ship. During the passage in the landing craft wireless silence was maintained by the signal section with each force which, as will be seen from the diagram, was equipped with two receivers—a No. 18 and a No. 46.

A beach-marking party had preceded our landing on a beach backed by high cliffs. The No. 18 sets were taken from their waterproof cases and fastened on the backs of the signallers. Ropes having been lowered over the cliff by the advance units, the signal-

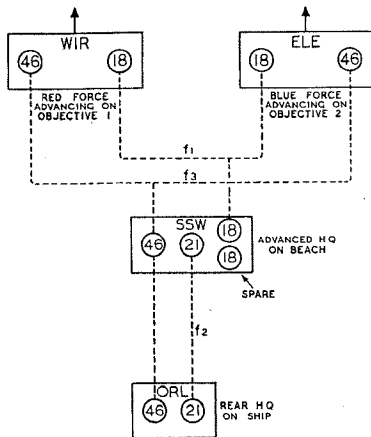

Signal diagram for the operation described, showing that each channel of communication is duplicated. Call signs of each "station" and types of transceiver used are indicated. Frequencies used:  $f_1$ , 7430;  $f_2$ , 5320;  $f_3$ , 8140 kc/s.

lers, some with sets on their backs, scaled the roof, cliff—no mean feat of strength and agility.

Having overcome slight "enemy" opposition, contact was made by the operators of the No. 46 sets with the headquarters ship, after which the two forces advanced inland toward their respective objectives.

On receiving the information that the landing had been successful, the advance headquarters embarked and proceeded to the beach.

During the first part of the

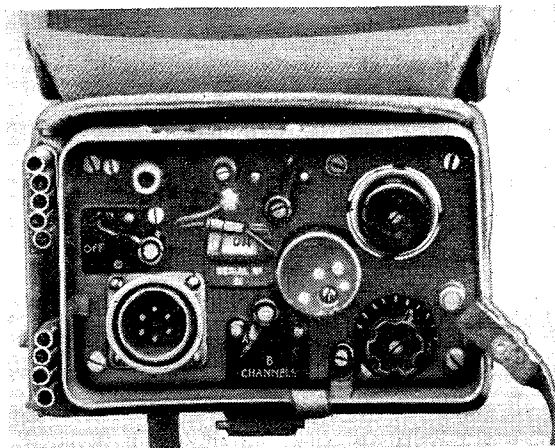

Operating panel of the No. 46 transceiver.

advance through barbed-wire entanglements and over rough country, contact was maintained between the two forces and headquarters. Even with the comparatively short ranges employed, signal strength dropped to R1 on one or two occasions in screened positions.

As soon as the advance headquarters had landed and taken up their position about 200 yards inland, contact was made with the two forces which were halted to get the No. 18 sets into operation and to reorganise signal procedure. It was now the task of the operator of the "46" set with each party to concentrate on maintaining communication with his opposite number in the other force, leaving communication with headquarters to the larger No. 18 set.

It should be pointed out that the No. 21 set shown in the diagram with the advance headquarters is a heavy transmitter-receiver which is carried by two or three men. For hauling up this heavy gear a rope "railway" was rigged up from beach to cliff top.

From the foregoing brief description of the exercise, which was typical of the continuous training undertaken by Commando signallers, it can be seen that the apparatus required must be capable of being set up quickly, of withstanding shocks, simple in operation and, as far as possible, waterproof.

An Instrument Mechanic is included in each operational section, and it is his job to maintain the gear in use, and to set the

apparatus to the frequencies selected for the operation in hand. His equipment includes spanners, screw-driver, soldering kit (a small blow-lamp is used for heating) and test meter.

The No. 18 set is a pack transceiver (combined transmitter - receiver in which some components are common to both) with a frequency coverage of from 6 to 9

Mc/s. This was briefly described in our issue of September, 1942.

An interesting, and very much lighter, set is the No. 46 transceiver designed especially for Combined Operations. At present it is not possible to give more than a few brief details of the design of this set, which is crystal controlled on three fixed frequencies. The panel is very neat in layout and includes a press-button send-receive switch, a three-channel selector switch, on-off switch with visual indicator, vernier tuning



The No. 46 set unpacked for stationary operation with a heavy type of aerial. The case on the right contains the two batteries.

**Commando Signals**

knob, aerial socket and six-pin connector for battery supply, phones and throat microphone.

The waterproofing of the set is completed by a rubber sheath passing over the plug and socket connector on the panel. The two combined HT/LT batteries (one is carried as a spare) are protected from dampness by being enclosed in a waterproof bag before being

positions corresponding to the predetermined frequencies.

One mode of carrying the No. 22 set is on a hand cart as shown on the accompanying photograph. The waterproof cover on the truck can be erected to provide protection for the operator as well as the set. These hand carts, the body of which can, if required, be lifted from the chassis, are used to transport

the normally conflicting qualities required in the tough fighting soldier and in the technician have been successfully combined in one of the newest wireless branches of the Services.

## HENLEY'S EDUCATION SCHEME

WE have received a copy of an illustrated booklet which is handed to every boy on entering the service of W. T. Henley's Telegraph Works Company and Henley's Tyre and Rubber Company. This booklet outlines a scheme which is intended to enable all youths joining the Henley organisation to see what chances there are open to them and how they can train themselves for their careers.

Dr. P. Dunsheath, director and chief engineer of W. T. Henley's Telegraph Works, as chairman of the Education Committee, has been largely responsible for the success of the scheme, which was launched in 1942.

Every boy is given the option of undertaking a course of training extending over a period of years. On a selected day each week, boys who have shown that they can benefit from such privileges and have been accepted for the course are released entirely from their normal duties in order that they may attend approved classes at selected educational institutions near to their place of employment. They are expected to devote themselves wholeheartedly to the courses laid down for them during this day, and to attend a recognised educational establishment of their own choosing at least one other evening in the week, for which purpose wherever practicable they will be released from shift work or overtime. In addition, they must undertake to carry out the homework in connection with their day course to the satisfaction of the education authorities.

The subjects selected for the day periods are of a more serious and fundamental nature, but a good deal of freedom is given in the selection of subjects for the evening courses. Boys are paid for the time spent at the day establishment, and all fees, both for the day and evening courses, are paid by Henley's.

The scheme is not only intended to produce better workmen, better foremen, better managers, but also better citizens, and in addition to every encouragement being given to the boys to enlarge their mental outlook, physical training class form an important part of the scheme.

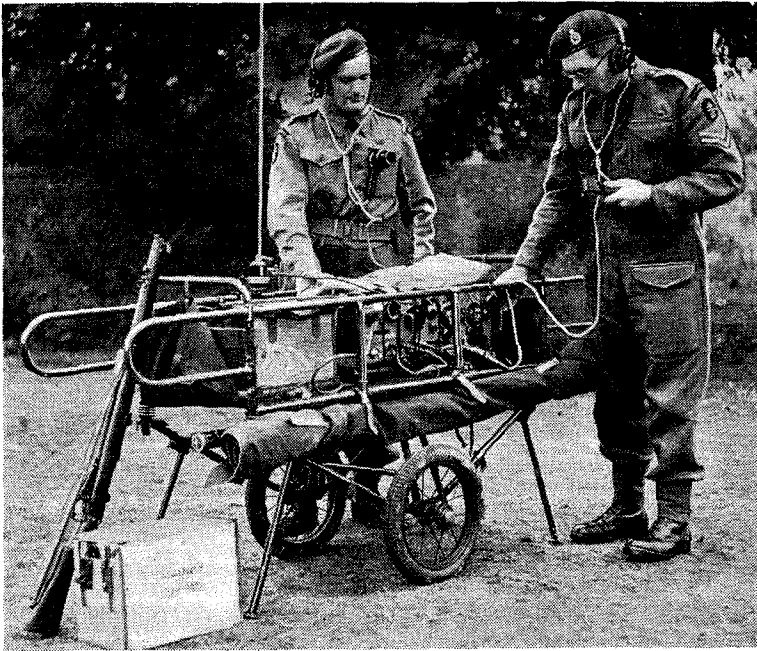

This complete station, the No. 22 set, can be carried on a light tubular-steel handcart, as illustrated.

inserted in the case which, carried on the operator's back, also contains headphones and laryngaphones.

The set itself is carried on the chest of the operator in a waterproof case measuring approximately 12x8x4in., and employs an 8ft. sectional rod aerial.

A much heavier set, the No. 22, is employed for headquarters work. It is a combined transmitter-receiver deriving its power from two 12-volt accumulators with which 30 hours continuous working is possible. A working range of some 30 to 40 miles is claimed for this set, which operates on phone, CW or MCW. Output is of the order of 3 watts. One of the many interesting points in design is a mechanical method of pre-setting the tuning to two frequencies. When rotated, the two dials automatically stop at

heavy apparatus over long distances.

Another method of transport for this set is as a three-man pack. The first carries the set in a special harness similar to an alpine carrier; the second the power unit on his back and two satchels containing the AF gear and the long fishing-rod aerial, and the third the large 12-volt accumulator.

A lighter transportable transmitter is the No. 21. This set, which derives its HT from a medium-sized accumulator through a vibrator, operates on phone, CW and MCW in the 19 to 31 and 4.2 to 7.5 Mc/s bands. A feature of the set is that it has provision for remote control.

This brief description of the work of Commando signallers, and of some of the gear they must be capable of operating and maintaining will, it is hoped, show that

# SINGLE-VALVE FREQUENCY DIVIDER

## Another Application of the "Transition" or Negative Transconductance Oscillator

By

PATRICK F. CUNDY,

A.M.I.E.E. (G2MQ)

THIS article describes theoretical and practical work to demonstrate the close analogy between the Herold "negative transconductance" oscillator and the two-valve Franklin or multivibrator oscillator, and shows how the negative transconductance oscillator, like the multivibrator, may be used as a frequency divider.

It has been customary to call the negative transconductance oscillator the "Transitron," but since no use is actually made of any transit time phenomenon the name is rather unfortunate. Throughout the present paper the arrangement will be referred to as the Herold oscillator, since it is

starts to flow, and since no increase in cathode current is possible the  $G_2$  current falls. The period of falling screen current  $I_{G_2}$  lasts until  $G_3$  is somewhere in the positive region and all electrons passing through  $G_2$  are accelerated onwards.  $I_{G_2}$  has then fallen to a value determined by the number of electrons colliding with the  $G_2$  structure and no further reduction in  $I_{G_2}$  can occur. The theoretical characteristic is therefore as shown in Fig. 1, and it will be noted that over the centre range this is the inverse of a normal triode  $I_a/E_g$  curve.

This characteristic is even more pronounced in the case of a heptode, in this case the  $G_1$  (oscillator grid) and the  $G_2$  (oscillator anode) are returned to cathode and the inverted characteristic appears between  $G_4$  (signal grid) and the  $G_3$  plus  $G_5$  screen. The reason for the higher negative slope is that the signal grid of a heptode is wound with a much closer pitch than the suppressor of a pentode and the limiting conditions occur with considerably less positive or negative potential (Fig. 1). A triode-

application considerably; this point will be dealt with more fully later on.

The heptode does not show as great an increase of slope as it might. The screen current consists of two parts, that which flows from  $G_3$  exhibiting the negative slope characteristic, while that from  $G_5$  exhibits a normal positive slope similar to that of the anode. The net screen current is determined by the difference between these two characteristics and the

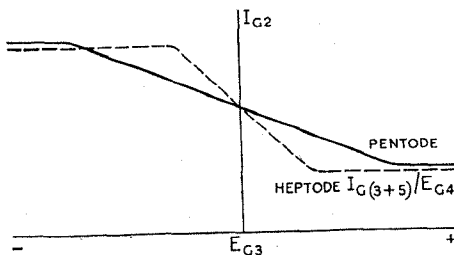

Fig. 1. Negative transconductance effect in pentode and heptode valves.

believed that the first published reference to an oscillator of this type was made under E. W. Herold's name.<sup>1</sup>

### Negative Transconductance Effect

If a normal pentode has its inner or working grid  $G_1$  returned to cathode or to some value of fixed bias it tends to set a limit to the total cathode current (providing no large change of screen voltage  $E_{G_2}$  occurs) and the suppressor potential will determine how this limited cathode current is divided between the anode and the screen. With a high negative potential on the suppressor grid  $G_3$  the anode current is cut off and all the cathode current flows to the screen  $G_2$ . As this negative potential is reduced there is no change in  $G_2$  current until a point is reached when anode current

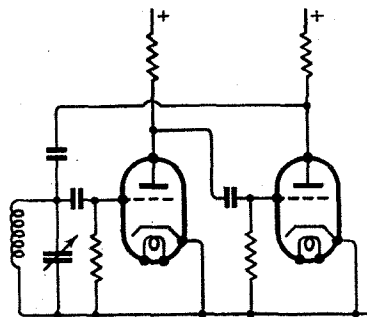

Fig. 2. Franklin two-valve oscillator.

hexode also shows this effect but the triode grid strapped internally to the  $G_3$  grid modifies its

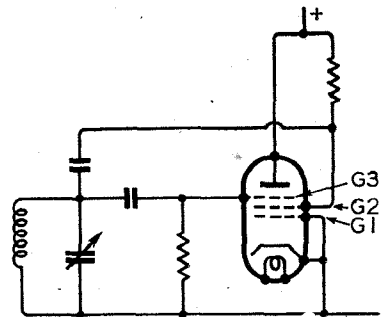

Fig. 3. Basic connections of the Herold oscillator.

value of the negative slope is not as high as it could be. A valve with the two parts of the screen brought out separately would show a further increase in negative slope, and, as will be mentioned later on, would have a further important advantage.

### Analogy Between Franklin and Herold Oscillators

In order to secure oscillations in a circuit associated with a triode valve it is necessary to feed back from the anode circuit a potential that is in phase with the grid voltage, and since the anode and grid potentials are normally in opposite phase, some external means must be found of securing additional phase reversal in the feedback path. In most single valve oscillators this is achieved by a second winding or a tapping point on the coil. A second valve may be used, however, to obtain this phase reversal, and the result



**Single-Valve Frequency Divider—** is the well-known Franklin oscillator (Fig. 2).

Since the pentode valve used as described above has an  $E_{G3}/I_{G2}$  characteristic which is the reverse

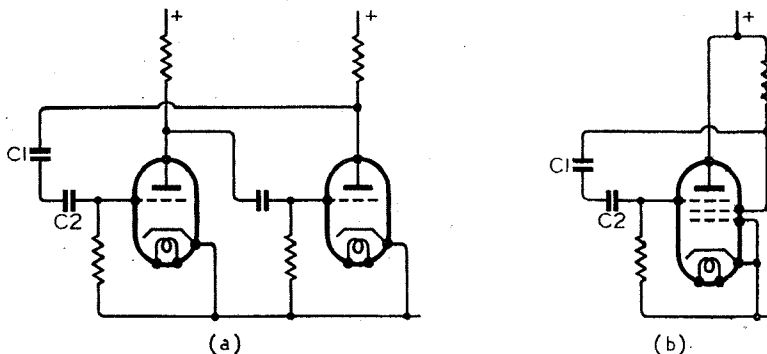

Fig. 4. Without the tuned circuit both the Franklin circuit (a) and Herold circuit (b) will continue to oscillate and can be used for frequency division.

of a normal triode  $I_a/E_g$  characteristic no external phase reversal is necessary, and oscillation is secure by coupling straight back from  $G_2$  (Fig. 3). This is basically the Herold oscillator. If the tuned circuit is omitted from a Franklin oscillator, the necessary phase relationship for oscillation is still present, and oscillation continues with a complicated wave form and a frequency largely determined by the resistance-capacity constants of the intervalve couplings. This is the multivibrator<sup>2</sup> (Fig. 4 (a)).

arrangement has been used as an oscilloscope time base,<sup>4</sup> but the implication that it could also be used as a frequency divider has not hitherto been explored as far as the author is aware.

**Operation of an Untuned Herold Oscillator**

A valve was set up in the circuit shown in Fig. 5, an oscillograph being placed in turn at the points indicated. The resulting waveforms are shown in Fig. 6 (not to scale). The theory of operation developed to fit in with these findings is as follows:

Starting from point (a) on the  $E_{G3}$  curve, the operating point is assumed to be far to the left of Fig. 1, that is  $E_{G3}$  is considerably negative. This charge slowly leaks away through the grid leak until the bend in the curve is reached. During this period there is no change in  $I_{G2}$ , and consequently no change in  $E_{G2}$  or  $I_a$ . As the charge falls the potential of  $G_3$  passes the bend and the  $G_2$  potential starts to rise rapidly; this in turn pulls  $G_3$  positive with it, occasioning a further sharp fall in  $I_{G2}$ , a rise in  $E_{G2}$ , and an increase in  $I_a$ , the operating point swinging abruptly far to the right of Fig. 1 ( $E_{G3}$  positive).  $E_{G3}$  is held positive by the condenser charge; this leaks away more rapidly than when the grid was negative because, in addition to the current flow through the grid

leak, there is also an electron current to the grid. Until this charge has fallen to the bend in the positive region no change occurs in the anode or screen current; when the bend is reached there is an increase in screen current, a fall in screen potential, and  $G_3$  is driven negative again. It is clear that the ratio of the periods B to C (Fig. 6) can never be 1 : 1 because of the grid current when  $G_3$  is positive; the lower the value of the grid leak (which means a larger condenser for the same frequency) the more nearly equal these periods will be. The effect of the triode grid, when a triode-hexode is used, is to increase very considerably the grid current in period C and shorten the duration to approximately 1/50th of period B.

**Methods of Synchronising**

Two possible points for injecting the synchronising signal are apparent, either at  $G_1$  or  $G_3$ . Although  $G_1$  is suggested in the

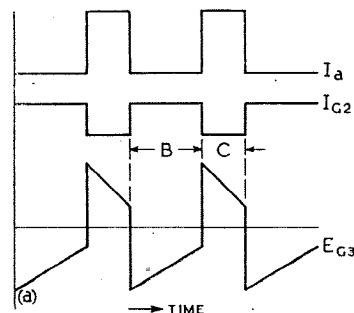

Fig. 6. Waveforms of anode current, screen current and suppressor grid voltage in the circuit of Fig. 5.

time base application mentioned it was not found possible to rely on this method for frequency divisions of a higher order than about 3 : 1. Injection on  $G_3$

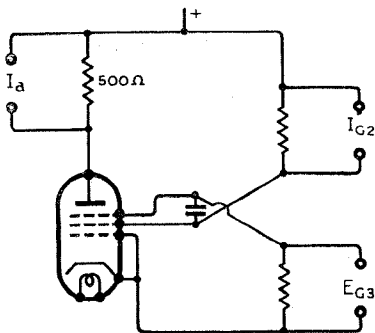

Fig. 5. Circuit of untuned Herold oscillator showing points at which oscillographic records of current and voltage were taken.

In practice,  $C_1$  and  $C_2$  are replaced by a single condenser of somewhat larger value than is used for the Franklin oscillator. Under certain conditions this arrangement can be made to divide frequencies.<sup>3</sup> If the tuned circuit is removed from a Herold

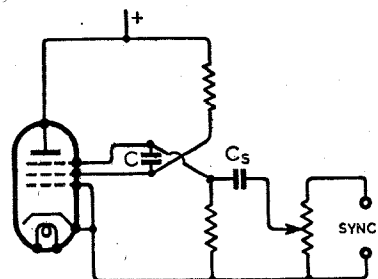

Fig. 7. Method of injecting synchronizing signal for frequency division.  $C_s = C/10$  (approx).



through a small condenser was more successful in practice (Fig. 7). A positive pulse will initiate the swing positive of G<sub>3</sub> potential or a negative pulse will initiate the swing negative of the G<sub>3</sub>. When, as is usual for divider service, the synchronising source is a sine wave, then both the positive and negative swings may be used,

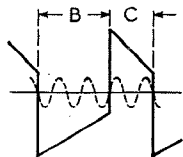

Fig. 8. Frequency division by four with B:C=5:3.

providing the ratio B to C in Fig. 6 is suitably adjusted. Fig. 8 shows the case for division by four when the ratio B to C is 5 : 3.

**Output Coupling**

The output of a Franklin oscillator or a multivibrator can be taken from grid or anode of either triode. The coupling must be fairly loose, however, and a buffer valve is usually necessary to prevent variation in the output circuit constants from upsetting the oscillation frequency or waveform. A multivibrator functioning as a divider thus requires three valves per dividing stage. An "Untuned Herold" oscillator could be coupled from either G<sub>3</sub> or G<sub>2</sub>, but since G<sub>3</sub> is already in use for the synchronising signal,

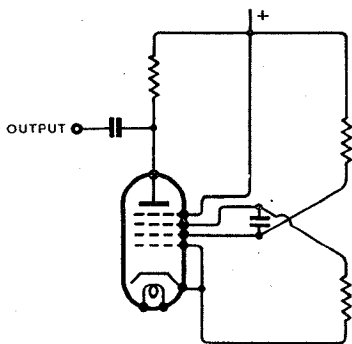

Fig. 9. In a hexode oscillator with separate screens the output could be taken from the anode without a buffer stage.

cathode and not used, G<sub>2</sub> would function as the G<sub>2</sub> in the pentode case, G<sub>3</sub> as the pentode suppressor, G<sub>4</sub> as the pentode anode which is at earth potential with respect to the signal, and the anode as the output electrode. G<sub>4</sub> would act as an electrostatic screen and the output would be isolated in the same manner as a Dow oscillator (Fig. 9). The number of valves per dividing stage would then be reduced to one.

**Performance of Apparatus**

A three-valve, crystal-con-

with a piece of black paper so that only the tips of the 100 kc/s waves are visible. The "extra" waves (appearing between the 100 kc/s wave tips) in the divided waveform are due to amplification by the divider and the harmonic amplifier of a strong second harmonic generated by the crystal oscillator; 20 kc/s harmonics are detectable up to 15 Mc/s with the amplifier anode circuit untuned, and well beyond 30 Mc/s when the amplifier anode circuit is tuned.

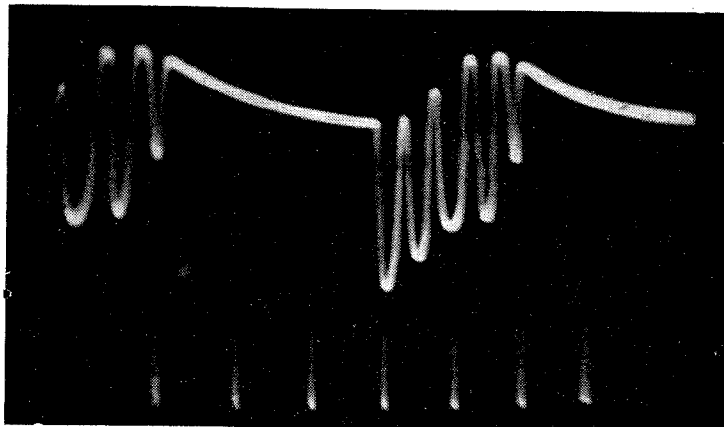

Fig. 10. Oscillograph of output from a three-stage frequency divider.

trolled frequency sub-standard has been constructed using the single-valve divider circuit. The first valve is a 1000 kc/s-100 kc/s dual crystal oscillator, the second valve is a 5 : 1 divider which may be switched into the 100 kc/s circuit, and the last valve is a harmonic amplifier. The oscillograph (Fig. 10) shows the output of the amplifier with the divider switched in and out. With the divider out the oscilloscope screen was covered

**Bibliography**

- <sup>1</sup> "Negative Resistance and Devices for Obtaining It," by E. W. Herold, *Proc. I.R.E.*, Oct. 1935.
  - <sup>2</sup> "Multivibrator Action," by E. Hughes, *Wireless World*, Nov. 1942.
  - <sup>3</sup> "Frequency Measurements," *Amateur Radio Handbook*, 2nd Ed., p. 219.
  - <sup>4</sup> "A Single-valve Time Base Circuit," by B. C. Fleming-Williams, *Wireless Engineer*, April 1940, p. 161.
- The references 2 and 3 are not the original publication of the relevant data, but are good recent expositions of the subjects.

**WARTIME "QUALITY" AMPLIFIER**

Since it was first introduced some nine years ago the "Wireless World" Quality Amplifier has enjoyed such constant popularity that all the back numbers containing descriptions of the various versions are now out of print. There is still a steady demand for information on the subject, and, to meet it, we are describing, in our December issue, wartime simplifications of the circuit designed to suit prevailing conditions.

**FREQUENCY CHECKING**

WITH the completion of a new 10-KW transmitter, WWY, at Beltsville, Maryland, the American National Bureau of Standards has extended its transmissions of standard frequencies, which are radiated throughout the 24 hours. The service now includes: Standard radio frequencies of 5, 10 and 15 Mc/s; standard audio frequencies; musical pitch (440 c/s corresponding to A above middle C); and time signals. The accuracy of the frequencies is better than 1 in 10<sup>7</sup>.  
Broadcasting stations, research establishments, and the Forces make extensive use of the transmissions.

# “Utility” Broadcast Receivers

**QUESTION No. 15. Assuming that it is decided we are to have a “utility” broadcast receiver, what, in the opinion of the Wireless World Brains Trust, is the most suitable circuit arrangement? W. FORD.**

**“CODON” argues the case for a superheterodyne.**

THE specification of a receiver grows from the performance desired, so let us first be clear about what is expected from the so-called “utility” receiver. (1) It must receive Home and Forces programmes under wartime conditions. (2) It must be as simple to operate as the sets to which the public has been accustomed for the past five or ten years. (3) It must be built as a sound engineering job to have a reasonable life; shortage of materials will continue for some time after the war, and in any case there must be some delay in restarting normal production, so the “utility” receiver will not be scrapped on Armistice night in the expectation of buying a new high-performance receiver next morning.

The two-valve detector-LF combination relies on reaction for the sensitivity and selectivity needed in all but the most favourable circumstances, and the use of reaction on the aerial circuit is not admissible to-day. It was bad enough in the early days when half the users of radio receivers had some technical knowledge, and the others regarded the apparatus with awe; to-day, nobody will

“Codon” considers that a det.-AF set like the standardised German *Kleinpfeifer* shown in this diagram (copied from a German manufacturer’s blueprint) would be quite unsuitable here

trouble to learn how to handle a wireless set, and the distribution of thousands of receivers capable of oscillating would cause pandemonium. The art of obtain-

ing adequate selectivity with the aid of reaction and volume control calls for even more skill than obtaining sufficient volume, and even for the reception of Home and Forces programmes selectivity may be necessary. It must be remembered that the “utility” receiver is required to work under wartime conditions (unlike the German *Volksempfänger*, which was a peacetime proposition), and this may still include operation during air raids; now the BBC must have expended much effort on their system which avoids a complete shut-down during air raids, but gives a service which may be reduced in strength and liable to fading in particular districts. It would be a pity to waste this service by providing receivers which could not profit by it because (a) they had no AVC, and (b) their selectivity was so poor that after dark any reduction in field-strength from the BBC would result in a neighbouring German station breaking through. The straight two-valve set is therefore, inadequate for wartime conditions.

If we are driven to a superheterodyne, what is the simplest type of such a receiver that can be made? A two-valve set containing frequency-changer, IF cir-

quency-changer, but its sensitivity would be very low. Reaction from the output valve on the IF circuits would help, and could not radiate at signal frequency, but an output pentode probably would not give smooth reaction and a band-pass circuit is a difficult subject for reaction. A scheme which is attractive on paper is to use frequency-changer, double-diode-triode, and output pentode, with reaction from the triode section of the DDT on the IF circuits. The additional AF gain from the triode section of the DDT would be very welcome but we are still up against the problem of applying reaction to an IF circuit which must (for adequate selectivity) consist of a band-pass transformer or other multi-circuit arrangement. In addition, the voltage at the diode will be very low, perhaps a tenth of a volt, so that it will not suffice to provide AVC of any kind; even if we use a special circuit in which the triode acts as AVC amplifier (either RF or DC) there is only the frequency-changer to control. Although the circuit has the attraction of very little increased HT current consumption (perhaps 1½ mA for a high-impedance DDT) it does not seem a very practical proposition.

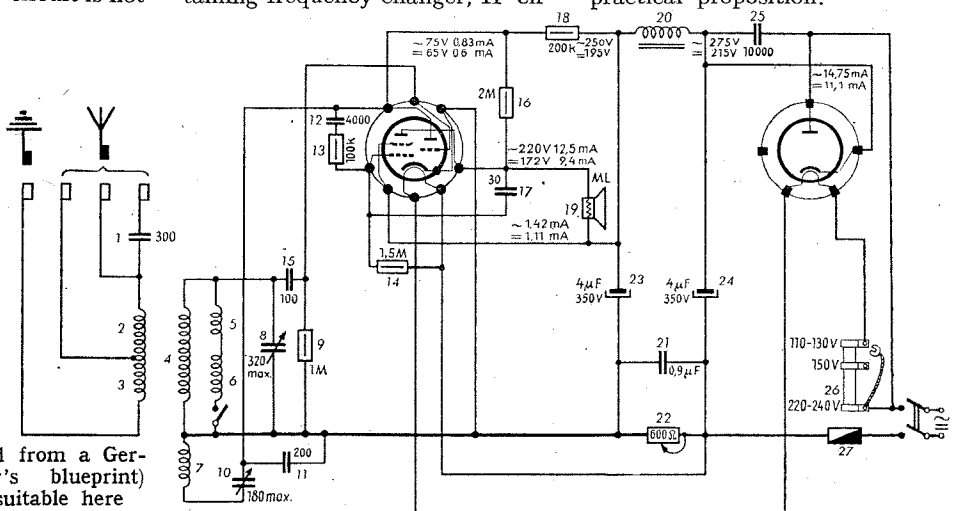

cuits but no-IF valve, and detector-output valve is the minimum; it could give adequate selectivity by means of the IF circuits, and a slight degree of AVC on the fre-

The next possibility is frequency-changer, IF valve, and double-diode-pentode output valve. Admittedly the DD-Pen is not a common type of valve,

# International Telecommunications

## Post-war Radio Developments

but it has been made and no doubt could be produced without undue difficulty. We now have reasonable sensitivity and selectivity without reaction, a fairly high signal level (say, 5 to 10 volts) at the diodes, which makes AVC possible, and both frequency-changer and IF valves to control so that AVC can be reasonably effective. This seems the most promising arrangement to try, and the power-supply system must be scrutinised for any possible economy now. The output valve will presumably be of high sensitivity but only moderate power-handling capacity, with an anode current of perhaps 20 to 25 mA; with only two other valves, the total anode current will be too small to energise the field of a loudspeaker with winding of normal resistance, and any increase of HT voltage above that required by the valves involves higher ratings of smoothing condensers, etc., so that a PM speaker is indicated. This should in itself be simpler to make, since it has no hum-bucking coil. We now need a smoothing choke (since the speaker field is no longer available for this purpose) which appears to involve additional iron and copper; but this can be more than off-set by omitting the mains transformer and building the set as an AC/DC model. Since 4-V 1-A valves are practically obsolete, it is assumed that 6.3-V valves would be used in any case, so that the heater consumption of a series-wired set presents no great difficulty. It would, however, mean that the set would have to be sold complete in cabinet, to protect the user against contact with the live chassis, etc., but in any case the idea of selling a loose receiver chassis and leaving the purchaser to find a housing for it is probably bad. Wood is likely to be more readily available for a cabinet than plastics, and the elaborate press tools required for a moulded cabinet would probably be prohibitive even if moulding material were available.

The suggested design is therefore a three-valve (+ rect.) AC/DC superhet. in a simple wooden cabinet, the valves being frequency-changer, IF amplifier, and double-diode-pentode as detector and output valve.

**I**N his inaugural address, delivered on October 7th, Col. Sir A. Stanley Angwin, Engineer-in-Chief of the G.P.O., the new President of the Institution of Electrical Engineers, dealt with the question of international organisation of telecommunications after the war and its repercussions on developments in this country.

After describing the existing machinery for formulating international regulations, Sir Stanley explained why the allocation of frequencies was the most difficult of all the problems to be dealt with. The growth of aviation and extended use of the frequency spectrum will accentuate these difficulties after the war. Rational technical considerations, rather than political, must in future serve as a guide.

International regulations must cover wavelengths ranging from roughly 5 metres to 30,000 metres. On the subject of shorter wavelengths, Sir Stanley said: "Under certain circumstances and over shorter distances this difficulty of interference may also occur in the very short wavelengths, and it is difficult to determine a border line at which it may be said that national regulation alone is sufficient and that there is no need for international regulation. The practicability of using relay stations, i.e., a receiving station associated with a re-transmission station, in order to extend the transmission distances of short and very short wavelengths, accentuates the need for agreement on allocation."

Stressing the need for radical changes in the present allocations, partly brought about by new applications of wireless developed during the war, the speaker urged that priority should be given to those mobile services—marine and aeronautical—for which there is no alternative to radio. "The needs of long-distance telegraph, telephone and broadcasting services must also be met by radio until further development of line facilities makes their partial or complete replacement possible." Concluding his remarks on this subject, he said: "A full de-

velopment of the art of communication can only be expected if a sound plan is designed and applied for the regulation of the ether. This must be based not only on specific allocation to services, but on other fundamental principles such as the regulation of the power of transmitters, methods of transmission and limitations of causes of interference. The necessity for these regulations is, perhaps, more apparent in the case of broadcasting than in other applications of radio."

### Future of Television

On the subject of television it was considered that the present standard of definition, which falls short of that accepted for cinema pictures, was the first field for advance. That, and the development of colour and stereoscopic transmission, will necessitate the use of much higher carrier frequencies.

"It is with a developing and expanding art such as television that international regulation and standardisation require most careful and judicious planning. Too early crystallisation will cramp development, but lack of co-ordination may lead to chaos. It is, perhaps, not too much to hope that some of the mistakes in the regulation of broadcasting may be avoided, and that such national regulation as may be necessary may be applied to act not only in the interests of television but in the interests of other services requiring to use a similar range of frequencies.

"How far the full exploitation of television will be divided between radio and line transmission has yet to be determined. The use of very much higher frequencies involves limits in the effective transmission coverage of radio. Transmission where necessary over long distances may be by radio relays or by wire, using one of the forms of co-axial cable. How far the employment of micro-waves for radio transmission or the new mechanism of electrical transmission by wave guides will meet the needs of television is one of the intriguing problems of the future."

# LOW-TENSION SOLDERING IRONS

## Hints on Construction

**T**HERE are two main advantages, in addition to decreased risk of electric shock, in using a comparatively low-voltage heating element (e.g. 12 to 40 volts) in a light soldering iron. Thick heater wire can be used, which is easy to handle in the construction and repair of elements and can fairly readily be obtained from old electric fire or flat-iron elements—a consideration in these times. Secondly, the iron can be run from accumulators if mains supplies are inconvenient or not available. The disadvantages are that such irons cannot economically be used with series resistance on DC mains, owing to the comparatively heavy current they require, and for use of AC mains a step-down transformer is necessary. The latter disadvantage, however, is not very serious, as suitable transformers are easily constructed and are not bulky.

There are two possibilities. Either an old or burnt-out mains-voltage electric soldering iron can be altered by the fitting of a low-voltage element in place of the original element, or an entirely new iron can be constructed if a non-standard type is needed for special work. In each case the first consideration is that of the low voltage heating element. This may consist of a length of comparatively thick wire (usually nickel-chrome) wound on a slip of mica. The wire may be obtained from an electric fire or flat-iron element. The length of this wire in the soldering iron element is determined by the ratio of the wattage required for the soldering iron, to the wattage of the fire or flat-iron element being used. Thus,

$$l_1 : l_2 :: W_1 : W_2 \text{ or } l_1 = \frac{l_2 W_1}{W_2}$$

where  $l_1$  is the required length of wire for the projected soldering iron element,  $l_2$  is the measured total length of wire in the fire or flat-iron element,  $W_1$  is the wattage of the projected iron and  $W_2$  the wattage of the fire or flat-iron element. An extra half or one

inch may be added to  $l_1$  to connect it to the power leads.

Two examples will be given. The first assumes that a 230-volt 450-watt flat-iron element is available, the wire on which when unwound is 16ft. long (the length will, of course, vary with the wattage of the element being used, its type, etc.). The wattage of the projected iron is, say, 65. Thus,  $l_2$  is 192 inches,  $W_2$  is 450. Then

$$l_1 = \frac{65 \times 192}{450} \text{ or } 27.7 \text{ inches}$$

approximately.

It would be safe to take 28 inches as the total length required, including sufficient to join on to the power leads.

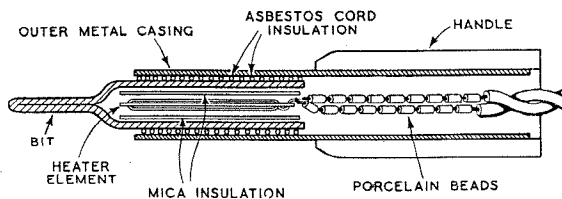

Fig. 1. Sectional sketch (not to scale) showing construction of the iron. The bit is made of a single piece of copper, bent to shape. To avoid losses, clearances between the heater element and the copper should be as small as possible.

The second example assumes that a fire element rated at 1.5 kW is available, with a length of 20ft. of wire.

$$l_1 = \frac{65 \times 240}{1,500} \text{ or } 13 \text{ inches}$$

approximately.

The current and voltage requirements have next to be found. The 450-watt element carries very nearly 2 amp. normally; the 1.5 kW element carries a trifle over 6.5 amps. Since each is to handle 65 watts, the voltage required, given by  $E = \frac{W}{I}$ , is  $\frac{65}{1.9}$  or approximately 35 volts for the 2 amp. element and  $\frac{65}{6.5}$  or 10

volts for the 6.5 amp. element. The former would be very suitable for use with a mains transformer, the latter for use with, say, two 6-volt car batteries in series.

Construction depends on the requirements of the user and what is available in the way of materials. Fig. 1 shows the structure of a light iron constructed by the author for instrument work. The attachment of the resistance wire of the element to the power leads is not very easy. Soldering is out of the question, of course, owing to the heat during work, and brazing, silver soldering and riveting all present awkward technical difficulties without the proper equipment. In the end, the author carried out a successful electric weld between the resistance wire and the copper lead, using a 60-ah. 2-volt accumulator. The method, referring to Fig. 2,

consists essentially of momentarily shorting the accumulator across the junction of resistance wire and copper lead, the current so passed being heavy enough to fuse the two together. It can be done with a clamp and one

movable welding electrode as shown. The power leads of the iron are then insulated from each other and the metal shaft of the iron by porcelain beads or short bits of glass tubing up to the point where they remain cool enough while in use for soldering to the flex leads of the power supply.

The size of the copper bit is not critical provided the element inside or beside it dissipates the required wattage. A large bit merely takes an inconveniently long time to reach working temperature, and if it is too large, the loss of heat through an excessive cooling surface may prevent it ever reaching the working heat. It has the advantage of holding a considerable body of heat so that it is not too quickly cooled when applied to largish work. A small bit gets very hot in a short time and this may cause pitting or burning; moreover, when



applied to large work, it cools very quickly. For instrument work, a small hot iron is very desirable, since its use avoids heat being spread to other parts of the instrument either through having to hold the iron on to the work for

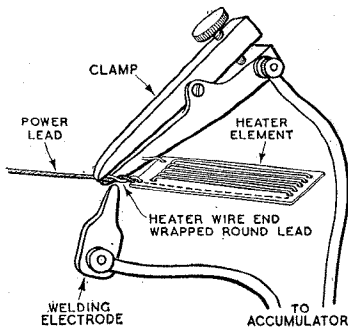

Fig. 2. Suggestions for an improvised electric welder for joining the power leads to the leading-out wires of the heater element. The accumulator leads must be of heavy cable, as short as possible.

a long time or through radiation from a large surface. If it is merely a matter of replacing a mains-voltage element by a low voltage one, the dimensions will have been fixed and need not be altered, provided the new element is rated at the same wattage as the old one.

A few details of a suitable transformer may be of service. The author removed the HT and LT secondaries from an old receiver type 80-watt mains transformer—counting the turns on one of the secondaries which was rated at 4 volts 2 amp. There were 25 turns, indicating 6 turns

per volt. To run a 35-volt iron, therefore, 215 turns of 20 SWG DCC wire were wound on as the secondary with taps at the 210th and 205th turn. To start work, the full 215 turns were used; when the iron was at working heat and had to be put aside for a while, it was switched to 205 turns, which kept it warm. More taps could, of course, be provided. To run a 10-volt 6.5 amp. iron, the secondary would have been 65 turns of, say, 16 or 18 SWG DCC wire, with taps at 57, 60 and 63 turns, and the leads from the secondary to the iron of ample gauge to carry the heavy current without overheating and to avoid voltage drop.

W. H. C.

AMERICAN SERVICE MANUALS

SERVICE data on a number of American broadcast sets is given in manuals now being published by Champion Electric Corporation, 84, Newman Street, London, W.1. The first volume, which has already appeared, deals with a number of Sparton and Emerson models; diagrams are given, with much data on voltage, alignment, chassis layouts, etc. Volumes II and III, which will probably be available by the time this appears in print, will each contain data on a number of Belmont and Crosley sets. The price of the volumes is 12s. 6d. each by post from the address given above.

**Kolster-Brandes.**—A recent notice in the electrical trades Press referred to Kolster-Brandes, Ltd., which went into voluntary liquidation on May 2nd, 1938, and not to the present company.

GALPINS

ELECTRICAL STORES

"FAIRVIEW,"

LONDON ROAD, WROTHAM, KENT.

TERMS: Cash with Order. No C.O.D.

Regret Orders from Eire and Northern Ireland cannot be accepted.

**SUPER SENSITIVE RELAYS**, multi leaf, P.O. type, very low M/A working, as new. Price 15/- each, post free.

**D.C. MOTOR**, shunt wound, condition as new, high grade, ball bearing, 1/4 h.p., 110 volts. Price 40/-, carriage paid.

**AUTO-TRANSFORMER**, 2,000 watts, tapped 0-110-200-220-240 volts, as new. Price £8.10.0, carriage paid.

**VOLTMETERS**, 2 1/2 in. dia., panel mounting moving coil, modern type, by famous maker 10 v. range, F.S.D. 5 m.a. Price 32/6, post free.

**AMPMETERS**, description as above. Ranges 0-1/2 and 0-20 amps., F.S.D. 15 m.a. State which reading required. Price 25/- each, post free.

**DUBILIER RESISTORS**, new lead and wire ends, 2 watt, 30,000 ohm, 1/8 each or 15/- per doz., post free. Ditto, 1 watt, 5,000 ohm., 8/6 per doz., post free.

**RESISTANCE MATS**, size 8in. by 6in., set of four. 80, 80, 150 and 690 ohms, carry 1/2 to 2 amp. Price, set of four, 5/-, post free.

**MOVING COIL MOVEMENTS**, needing slight repair, modern type, famous makers, deflection 10 m.a. Price 15/-, post free.

**RECORDING AMPMETER**, in ironclad case, meter movement wants repair, no pen, clock perfect, range 0-3 amps. Price £7, carr. paid.

**MOTOR-DRIVEN PUMP**, for oil or water, motor 220v. D.C., 1 amp., 1,250 r.p.m., maker Keith Blackman. Price £6 10s., carr. paid.

**200 AMP. KNIFE SWITCHES**, S.P., D.T., in first-class condition. 15/- each.

**200 AMP. CABLE**, V.I.R., as new, rubber cover perfect, size 37/13, lengths 80 to 40 yds. Price in lengths, 5/- per yard, carr. paid.

**ROTARY CONVERTOR**, D.C. to D.C., input 11 volts, output 1,100 volts, 80 watts, will operate successfully on 6 volt input. Price 50/-.

**MASSIVE GUNMETAL WINCH**, complete with long handle, for use with 3/4 in. dia. wire cable weight 50 lbs., condition as new. Price £3 carriage paid.

**ELECTRIC LIGHT CHECK METERS**, well-known makers, first-class condition, electrically guaranteed, for A.C. mains, 200/250 volts 50 cy. 1 phase 5 amp. load, 10/- each; 10 amp. load, 12/6, carriage 1/-.

**1/2 WATT WIRE END RESISTANCES**, new and unused, assorted sizes (our assortment). 6/- per doz., post free.

**SOLID BRASS LAMPS** (wing type), one hole mounting, fitted double contact, S.B.C. holder, and 12 volt 16 watt bulb. Price 3/6 each, post free, or 30/- per doz., carriage paid.

**TUNGSTEN CONTACTS**, 1/2 in. dia., a pair mounted on spring blades, also two high quality pure silver contacts, 3/4 in. dia., also on spring blades, fit for heavy duty, new and unused. There is enough base to remove for other work. Price, the set of four contacts, 5/-, post free.

**REDUCTION GEAR BOX**, right angle drive, ratio 50 to 1, ball bearing, shafts 7/16in. and 5/16in., in new condition. Price 25/- each, carr. paid.

**ROTARY CONVERTER**, D.C. to A.C. Input 22 volts D.C. (twenty-two). Output 100 volts at 140 M/A, 50 cycle, single phase, ball bearing, in first-class condition, no smoothing. Price £5, carr. paid.

Books issued in conjunction with "Wireless World"

	Net Price	By Post
FOUNDATIONS OF WIRELESS. Fourth Edition, by M. G. Scroggie, in preparation ...	7/6	7/10
TELEVISION RECEIVING EQUIPMENT, by W. T. Cocking ...	10/6	10/10
RADIO LABORATORY HANDBOOK, by M. G. Scroggie. Second Edition ...	12/6	12/11
WIRELESS SERVICING; MANUAL, by W. T. Cocking. Sixth Edition ...	7/6	7/10
HANDBOOK OF TECHNICAL INSTRUCTION FOR WIRELESS TELEGRAPHISTS, by H. M. Dowsett and L. E. Q. Walker. Seventh Edition ...	30/-	30/7
WIRELESS DIRECTION FINDING, by R. Keen. Third Edition ...	30/-	30/7
RADIO INTERFERENCE SUPPRESSION, by G. W. Ingram ...	5/-	5/4
LEARNING MORSE. 335th thousand ...	6d.	7 1/2d.
INTRODUCTION TO VALVES, by F. E. Hendersen ...	5/-	5/4
VALVE REPLACEMENT MANUAL, by A. C. Farnell and A. Woffenden ...	6/-	6/2

Obtainable from leading booksellers or by post from

ILIFFE & SONS LTD., Dorset House, Stamford Street, London, S.E1

## B.B.C.'s FUTURE

SOME of the technical problems that the B.B.C. will have to face when reorganising its service after the war were recently reviewed by Sir Noel Ashbridge, the new Deputy Director-General of the Corporation. The occasion was a luncheon of the Radio Industries Club, of which Sir Noel is President; the members took the opportunity of congratulating him on his appointment.

Sir Noel pointed out that, thanks to the installation of much new plant for war purposes, the B.B.C. should be in a position to give its home listeners a better service when this apparatus could be turned to peacetime uses. Many changes might take place, but it was probable that the long-wave station would have to be retained in order to serve isolated communities.

On the question of possible uses of ultra-short waves and frequency modulation, it was emphasised that the significant thing here was the use of very short waves for a broadcasting service—that in itself was a revolutionary and important change, and the method of modulating the waves was a matter which followed from it. FM had its virtues, but it was not an essential part of a USW distribution system, of which one of the principal advantages was the possibility of providing a large number of programme channels. Here Sir Noel touched upon the programme side; did we really want a great multiplicity of programmes, and would it not be better to concentrate, say, on three first-rate ones instead of 12 of a mediocre standard?

In reinstating the television service, we will have the alternative of restarting soon after the war ends with virtually the pre-war standards, or of waiting for a very con-

siderable time until a much more advanced system can be put into operation. Sir Noel considered as quite impracticable the suggestion that, after a short wait of a year or less, it would be possible to put into operation a system with substantial improvements over that of 1939; there is a wide gulf between the laboratory stage and the operational stage.

Oversea broadcasting on short waves would continue to be an important side of the B.B.C.'s work, but Sir Noel thought that the ultimate success of this service would depend on the extent to which the transmissions were received abroad by "diversity" and similar methods, with subsequent rediffusion to local listeners.

## RADIO INDUSTRY COUNCIL

THE formation of the Radio Industry Council, which is representative of the Radio Manufacturers' Association, the British Radio Valve Manufacturers' Association and the Radio Component Manufacturers' Federation, was announced at the end of September.

The official announcement states:

"This Council will present the unified view of the manufacturing side of the radio industry in all matters of common concern and will represent and speak for that side of the industry as a whole, particularly in regard to the many problems which will face it in the post-war period."

F. B. Duncan, of Marconiphone, Chairman of the R.M.A. for the current year, has been elected Chairman of the Council on which there are four representatives of each of the associations.

The offices of the Council are at 59, Russell Square, London, W.C.1., telephone, Museum 4033, and the Secretary is R. P. Browne, O.B.E., B.Sc.

## U.S. POST-WAR SETS

PLANS for the production of sets in the United States immediately after the war have been laid by American manufacturers. From the plans it appears new sets, including combined AM/FM models, are to be available within about two months of the cessation of hostilities.

Referring to television, our American contemporary, *Broadcasting*, states: "It is still an unknown quantity on anything approaching a national basis. There must be television transmissions on something other than a localised basis before mass production of sets is undertaken." It is reported that the mass production of cathode-ray tubes for the armed forces has made it possible to reduce the cost of the sizes likely to be used in home television sets from \$80 to \$20.

## DEATH OF AMERICAN PIONEER

WITH the recent death of John S. Stone at the age of 74, America has lost one of the last of its wireless pioneers. Dr. Lee de Forest, with whom he was associated for many years, writes in the *Proceedings of the Institute of Radio Engineers*:

"The radio engineering profession has lost one of the few who remained of the original pioneers of wireless. And none of those early researchers into the great new realm revealed by the immortal experiments of Hertz can begin to compare with Stone in clear-sighted mathematical analyses of the basic principles on which the science of radio is founded. He was the first of us all to reduce to concise analytical terms the fundamentals of synchronism, mapping precisely the laws of resonant, tuned circuits, then but dimly understood."

## LIFEBOAT RADIO

A TECHNICAL Committee has been set up by the Ministry of War Transport to enquire into the efficiency of the radio equipment of lifeboats.

The Radio Officers' Union, which was represented on the Committee, reports that investigation reveals that the occasions when successful use was made of lifeboats' radio equipment does not amount to as good a percentage as it would wish. Failures were found to be due to a number of causes in which, of course, the destruction of the gear and the boats figured largely.

In cases where the apparatus failed to function after being safely transferred to the boats the cause

**BI-DIRECTIONAL LOUDSPEAKER**, one of a large number used in the public-address system developed by Arden Acoustic Laboratories and recently installed at the L.N.E.R. Waverley Station, Edinburgh. This loudspeaker is designed to radiate a narrow channel of clear speech, to confine announcements to any particular platform, and to prevent intelligible speech being heard on adjacent platforms to which the information is not applicable.

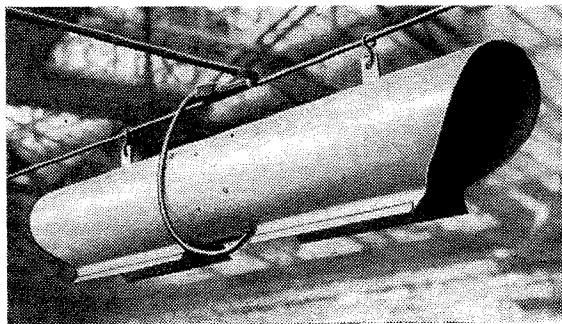

has, in several instances, been the accumulator. The small unspillable type used is said to require more attention than the ordinary wet type, and the R.O.U. stresses the necessity of giving every attention to the equipment.

**B.B.C. NEWS ON SHORT WAVES**

A CONSIDERABLE reshuffling of times and wavelengths took place in the B.B.C. European Service on October 4th. This was necessitated by the return to Standard Time on the Continent.

In addition to these changes, a growing number of new call signs are being used by the B.B.C. The latest newcomers are:—

GVZ 9.64 Mc/s 31.12 m. GWE 15.44 19.44  
 GWQ 15.07 19.91 GVQ 17.73 16.92  
 GWD 15.42 19.46

The latest schedule of news bulletins broadcast by the B.B.C. in English on short waves is given below. The times are BST.

0015†	25.53, 25.68, 30.53, 31.32
0045†	25.53, 25.68, 30.53, 31.32
0206	25.68, 30.53, 31.32, 48.43, 49.10
0345	25.68, 30.53, 30.96, 31.32, 41.96, 42.13, 44.15†
0415†	42.46, 48.43, 49.10
0530	25.68, 30.53, 30.96, 31.32, 42.13, 48.43, 49.10
0700	19.44, 19.91, 25.53, 25.68, 30.53
0900	31.55, 42.13
1000	25(2), 31(4), 41(2), 49
1200	13.97, 16.79, 16.84 19.42, 19.44, 19.60, 19.91, 25.53
1400	13.97, 16.64, 16.79, 16.84, 16.92, 19.44, 19.60, 19.91, 25.53
1600	13.97, 16.64, 16.79, 16.84, 16.92, 19.44, 19.46, 19.60, 24.92, 25.53, 25.68, 31.55
1700	16.59, 16.64, 16.92, 19.60, 19.66, 25.53
1745	24.80, 25.38, 41.49, 49.10
1900	16.79, 16.92, 19.66, 19.82, 25.20, 25.53, 31.25, 31.55
2045	16.92, 19.66, 25.53, 31.25
2145	16.79, 19.46, 25.29, 31.55, 42.46
2245†	25.53, 25.68, 30.53, 31.32, 31.61, 41.32, 41.75, 41.96, 48.98, 49.42, 49.59, 49.92
2300	31.55, 42.46
2345	25.53, 25.68, 30.53, 31.32

† Sundays only. ‡ Sundays excepted.

Where the actual wavelength on which a transmission is broadcast is not known a bracketed figure is given to indicate the number of wavelengths employed in that band.

**PORTABLE RECORDING TREND**

IN the recent seventeenth broadcast of the "B.B.C. Close-Up" series dealing with its recording crews, an engineer, M. Pulling, stated that the trend in recording equipment for "on-the-spot" work was towards a light and convenient design that could be used by a one-man commentator-cum-operator. The method to be employed in this development was not mentioned.

In this connection it is interesting to note that men of the U.S. Army Air Force on reconnaissance over enemy territory can now dictate their observations to a new recorder. The magnetic method on steel wire is the system used, and more than 60 minutes' continuous speech can be recorded on a spool containing nearly 4,000 yards of

wire. The sounds can subsequently be erased and the wire used again. It is reported that the entire mechanism is contained in a small box weighing about 9lb.

**IN BRIEF**

**I.E.E. Nikola Tesla Commemoration.**—At an ordinary meeting to be held at 3 p.m. on November 25th at the Institution of Electrical Engineers, Dr. A. P. M. Fleming will lecture on the life and work of Nikola Tesla, who died early this year, and whose name was primarily linked with projects for the wireless transmission of power. The lecture will be illustrated by examples of his experimental work.

**B.B.C. in Canada.**—S. J. de Lotbinière, who for many years was in charge of the B.B.C. Outside Broadcast Department and was recently appointed Director of Empire Programmes, is going to Canada to open a B.B.C. office in Toronto.

**Wireless Section, I.E.E.**—On November 3rd, J. Kemp will deliver a paper before the Wireless Section on "Wave Guides in Electrical Communication." K. I. Jones and D. A. Bell will open a discussion on "The Role of Ultra-high Frequencies in Post-war Broadcasting" at the meeting on November 16th. "Enemy Airborne Radio Equipment" is the subject of the paper to be given by C. P. Edwards on November 24th. Each of these meetings commences at 5.30 p.m.

**Brit.I.R.E.**—John L. Baird will lecture on "Colour and Stereoscopic Television" at a meeting of the British Institution of Radio Engineers to be held at 6.30 p.m. on October 28th at the Institution of Structural Engineers, 11, Upper Belgrave Street, S.W.1.

**Polyglot.**—In a recent review of the progress of the overseas services of the Nazi broadcasting organisation, which began regular short-wave transmission in 1933, the German journal *Weltrundfunk* announced that news bulletins are now broadcast in 53 languages.

**Scientific Photography.**—"The Photography of Cathode-ray Oscillograph Traces" is the subject of papers to be given by N. Hendry and W. Nethercot at a meeting of the Association for Scientific Photography to be held at 2.30 on Saturday, November 13th, at the Institution of Electrical Engineers, Savoy Street, London, W.C.2.

**Interchanging Valves.**—We have received from V.E.S., 4, Melthorne Drive, Ruislip, Middlesex, a copy of their publication "Valves and Their Interchangeability." It shows how, with the aid of V.E.S. valve base adaptors, substitutes can be found for over 250 British and American valves of various types. Copies of the booklet may be obtained from the above address, price 7d., including postage.

**Electrical Industries Red Cross Fund.**—Among names appearing in the latest lists of subscriptions to this Fund are: E. K. Cole, Ltd. (£300); Garforth Radio Services (£2 2s.). Contributions are still urgently needed; details of the appeal can be obtained from the Joint Secretaries, c/o The E.D.A., 2, Savoy Hill, London, W.C.2.

**CROWNAME**

RADIO COMPONENTS

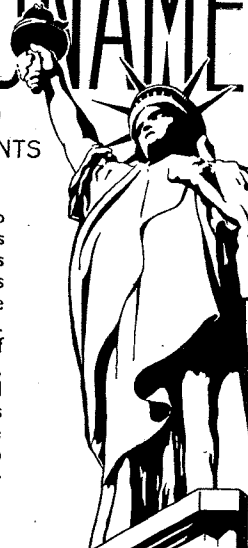

THE radio industry is contributing its share towards the assurance of a free world. As a part of that industry, CROWE will continue its peacetime leadership when the assurance is won.

**CROWE NAME PLATE AND MANUFACTURING CO. CHICAGO, ILL. U.S.A.**

Exclusively Represented by

**Frank Heaver Ltd. Kingsley Road, Bideford, N. Devon**



**Come lovely Flowers**

And so it is that from the darkness of the present hour will emerge a brighter day when the

brain and brawn of modern industry will be utilised in further peacetime products and pursuits. While serving the Government to-day we are broadening both creative and manufacturing possibilities for a happier world to-morrow. Astatic engineers are available to work in co-operation with electronic engineers in the development of new wartime equipment, especially as it may have to do with pickup and transmission of sound. Astatic crystal microphones, pickups, cartridges and recording devices will be available again for your use when those brighter days are here.

Register your name with our Representative for your future benefit.



**THE ASTATIC CORPORATION YOUNGSTOWN, OHIO, U.S.A. TORONTO, CANADA.**

Exclusively Represented by

**Frank Heaver Ltd. Kingsley Road, Bideford, N. Devon.**



## Letters to the Editor

# Improving the Ohmmeter : Public Taste in Reproduction : "Tracking Arm" or "Tone Arm" ?

### Design of Ohmmeters

THE recent article by F. Livingston Hogg on the design of ohmmeters induces me to comment on certain aspects of the fundamental design of instruments of the type described which does not in the past appear to have received adequate consideration. I should point out at the outset that my remarks apply only to multi-range ohmmeters in which it is desired to attain the best possible performance of which this type of instrument is capable, and it may be remarked that if every precaution is taken, the performance can be of quite high order.

A feature of this type of ohmmeter is the non-linear scale, and the fact that the inherent percentage accuracy with which a resistance can be measured varies considerably according as the reading occurs near mid-scale, where the accuracy is highest, or near either end of the scale, where the accuracy falls to zero. It will be recognised that this is quite different from the ordinary uniformly divided scale of which the accuracy is highest at full scale. A special feature of multi-range instruments is that the high accuracy only needs to be maintained over a range of resistance values governed by the ratio between successive ranges. The most convenient ratio between successive ranges is evidently 10 and it therefore follows that the best performance needs to be maintained over one decade. The most convenient decade is one running from 1 to 10 or a decimal multiple or submultiple thereof.

The best overall performance is clearly attained when the chosen decade covers the greatest possible length of the instrument scale, and when the maximum deviation of the inherent accuracy at any reading from the mean accuracy over the decade is a minimum. Both of these criteria are satisfied by a mid-scale value of  $(10)^{\frac{1}{2}} = 3.162$  or decimal multiple thereof, and not with the usually adopted mid-scale

values of 5 or 10. In addition, a further advantage results from the choice of 3.162 as mid-scale value in that the two auxiliary decades which can be accommodated on the scale, one above and one below the primary decade, are each of equal length, whereas they are unequal for other mid-scale values.

The accompanying table compares the performance with the alternative mid-scale values, and there is little doubt that, if a ratio between successive ranges of 10

highest resistance value which can be *accurately* measured on it; that is, the upper value of the principal decade, and not by some ultra-high value which can only be measured with a probable error approaching 100 per cent., and which only leads to confusion in use. An example of the latter arrangement is to be found in an otherwise excellent commercial instrument which has three ranges called 10,000 ohms, 100,000 ohms and 1 megohm respectively. How, then, is one to guess that a resist-

Mid-Scale Value	3.162	5	10
	Per cent.	Per cent.	Per cent.
Scale length occupied by decade 1-10 as percentage of total scale . . . . .	51.6	50	40.9
Maximum deviation of accuracy from mean accuracy over decade 1-10 as percentage of latter . . . . .	15.6	28.7	43.5
Scale length occupied by decade 0.1-10 as percentage of length of decade 10-100 . . . . .	100	50.1	19.8

is presumed, the optimum mid-scale value is 3.162. In addition, it is suggested that commercial multi-range ohmmeters of the type under discussion should have the principal decade marked in black and the supplementary portion of the scale on either side of it marked in red, in a similar manner to that adopted for the C and D scales of normal slide rules having extended scales. A measurement which results in a reading on the red portion of the scale then gives prompt warning that, for greater accuracy, a higher or lower range should be used, as the case may be. In the event of a ratio between ranges of 100 being adopted, the optimum mid-scale value is  $(100)^{\frac{1}{2}} = 10$ , which gives two decades, 1-10 and 10-100, of equal length and which should both be marked in black, thus corresponding to the A and B scales of a slide rule.

If the arrangement suggested be adopted it would seem logical to name each range after the

ance known to be about 2,000 ohms should, for greatest accuracy, be measured on the 1-megohm range?

P. d' E. STOWELL.  
Edinburgh, 3.

[The author writes: I read Mr. Stowell's letter with great interest, and would point out that his analysis of the accuracies of various decades leads to the following conclusion: The most accurate decade on any scale of the type under discussion runs from mid-scale value times  $10^{\frac{1}{2}}$  to mid-scale value divided by  $10^{\frac{1}{2}}$ .

It is not essential that this decade run from 1 to 10, in fact it may be undesirable for it to do so. In practice the actual mid-scale value chosen usually depends essentially on other considerations. If on the high ohmmeter we changed to a mid-scale figure of 3.162, we could have either 0.3162 megohm or 3.162 megohms for our highest range. The lower figure is often too low, and would limit the use-



fulness of the instrument. The higher figure would necessitate a voltage of over 400 volts on the prods unless a very much more sensitive, and therefore less robust, meter were used.

On the low ohmmeter, most of the instruments I have made have had a mid-scale value of 0.35 ohm, but they are harder to line up than when 0.5 ohm is used, and the practical difference is usually negligible.

On the other hand, I consider Mr. Stowell's suggestion for marking the most accurate decade an excellent one. I think that the mid-scale value should be chosen from practical considerations, and the accurate decade marked, as suggested; or else the other decades might be bracketed off and marked, "Use higher range" or "Use lower range." The latter would eliminate the necessity for two-colour printing.

I agree wholeheartedly with Mr. Stowell's remarks about the misleading descriptions on some universal meters. My personal preference is that a decade multiplying factor be specified. Every time I use a certain type of instrument a mental calculation has to be made as to what the range factor really is. A good instrument therefore comes in for disparagement, which would not have been the case had the makers adopted the point of view expressed.—Ed.]

**Musical Taste**

I WOULD like to make a protest against the view, expressed by several of your correspondents and now by your contributor "Diallist," that listeners to jazz music are particularly liable to prefer topless reproduction in order to "palliate the horrid noises" produced by jazz orchestras. Whilst I admit that there are many so-called jazz fans who do prefer excessive top cut, those who really listen to music (jazz or otherwise) always, I find, prefer the best reproduction available. The noises are certainly not horrid if listened to in the right way, or they would be turned off completely; not merely muffled. Incidentally, the products of crooners and dance bands are in no sense jazz.

In my opinion, the causes of the prevalent taste for "mellow" tone are (in order of importance)

- (a) sales propoganda in the early days of the moving coil speaker;
- (b) valve hiss, harmonic distortion and noise from interfering stations, the effects which are all reduced by top cut,
- (c) use of radio as a background for other activities. It is surprisingly difficult to "talk down" a high fidelity receiver even when it is operated at a very low acoustic level.

P. B. FELLGETT.  
Cambridge.

**Pick-up "Tracking Arms"**

MAY I thank Mr. A. C. Robb (your October issue) for proffering the term "tracking arm" in place of my suggestion, "carrying arm" for pick-ups?

Actually, in the first draft of my letter, in which this point was raised (June, 1943, issue), I included the term as an alternative, but eventually deleted it, as it has a direct disc recording connotation, e.g. cutting-head tracking arm (mechanism), etc., and if ever used without the description "pick-up" it might cause confusion. Of course, neither term is original, as both have been used before in gramophonic literature, but the important consideration is to standardise on one or the other, in preference to the misnomer "tone arm."

DONALD W. ALDOUS.  
Torquay, Devon.

**BOOK RECEIVED**

**Radio Control for Model Aircraft.** By Peter Hunt.—Intended to enable a model-aircraft enthusiast to construct a radio-controlled model, this book begins with a brief outline of radio communication, and continues with details of suitable transmitters, receivers, relays and their adjustment, selector mechanisms and servo motors, audio-frequency control, closing with installation methods. Many circuits and photographs are given. Of course, as the author mentions, under wartime conditions amateur radio transmissions are not permissible, and only experiments with miniature receivers can be undertaken at present. Pp. 63. Published by Harborough Publishing Company, Allen House, Newark Street, Leicester. Price 2s.

**GOODS FOR EXPORT**

The fact that goods made of raw materials in short supply owing to war conditions are advertised in this journal should not be taken as an indication that they are necessarily available for export.

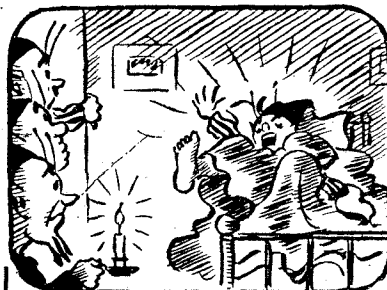

THE "FLUXITE QUINS" AT WORK

Young Ol had a nightmare last night,  
All due to a rash oversight.  
Guilty conscience, no doubt,  
Fancy wiring without  
The wonderful help of FLUXITE.

See that FLUXITE is always by you—in the house—garage—workshop—wherever speedy soldering is needed. Used for over 30 years in Government works and by leading engineers and manufacturers. Of all Ironmongers—in tins, 8d., 1/4 and 2/8.

Ask to see the FLUXITE SMALL-SPACE SOLDERING SET—compact but substantial—complete with full instructions, 7/6.

TO CYCLISTS! Your wheels will NOT keep round and true unless the spokes are tied with fine wire at the crossings AND SOLDERED. This makes a much stronger wheel. It's simple—with FLUXITE—but IMPORTANT.

The FLUXITE GUN puts FLUXITE where you want it by a simple pressure. Price 1/6, or filled; 2/6.



ALL MECHANICS WILL HAVE

**FLUXITE**

IT SIMPLIFIES ALL SOLDERING

Write for Book on the ART OF "SOFT" SOLDERING and for Leaflets on CASE-HARDENING STEEL and TEMPERING TOOLS with FLUXITE. Price 1d. each.

**FLUXITE LTD.**  
(Dept. W.W.), Bermondsey Street, S.E.1.

## "STREAMLINED" AERIALS

A FRAME aerial, particularly suitable for use on a radio-controlled aircraft, is wound so as to present minimum air-drag in the direction of motion of the craft. In one arrangement the coils are wound as on the surface of a cone, i.e., with progressively increasing diameters. They are then slightly stretched out along the common axis, and are finally turned or "flattened," so that all the coils be substantially in the plane containing that axis. This gives a streamlined contour in the direction of motion. In practice, the coils are wound directly on a plane wedge-shaped former.

Alternatively, the aerial may consist of a series of flat coils arranged in spaced groups or sections, each section being slightly larger in diameter than the one preceding it, so that the complete assembly fits conveniently into a streamlined casing. In addition, each section may consist of two separate but similar windings, set at right angles to each other.

*Standard Telephones and Cables, Ltd. (communicated by International Standard Electric Corpn.). Application date February 27th, 1942. No. 552949.*

## SHORT-WAVE AERIALS

FOR television and certain other forms of signalling, it is desirable that the impedance of the aerial should remain approximately constant over a given range of wavelengths. One known aerial arrangement of this kind consists of three parallel wires, separated by only a small fraction of the mean operating wavelength. The middle wire is broken at its centre and connected to a pair of feed-lines, the two outer wires are continuous and all three wires are connected together or short-circuited at each end.

Owing to their close proximity and consequent tight coupling, the currents flowing through any given cross-section of the system will be in the same direction, of equal amplitude, and of the same instantaneous phase.

The inventors have discovered that if instead of simply short-circuiting the

## A Selection of the More Interesting Radio Developments

outer extremities of the wires they are bonded together for a distance extending for, say, one-tenth of their total length, as measured from each end, the impedance of the aerial as a whole will remain substantially constant over a frequency variation of from 56 to 66 megacycles.

*Philips Lamps, Ltd. (communicated by N. V. Philips Gloeilampenfabrieken). Application date October 31st, 1941. No. 552911.*

## TRIGGERED RELAYS

THE figure shows a two-stage relay which is triggered by specific values of the applied input voltage, so that it can be used, say, in combination with a photo-electric cell to operate a load circuit in response to critical values of the prevailing light intensity. The arrangement will also serve to deliver constant square-shaped pulses in response to a sinusoidal input wave or to any wave having a periodically repeated slope, irrespective of the steepness of that slope.

The anode of the valve  $V_1$  is coupled to the grid of  $V_2$  through resistances  $R_1$ ,  $R_2$ ,  $R_3$ , the resistance  $R_2$  being shunted by a condenser  $C$  if it is desired to introduce a given delay. In addition, both valves are intercoupled by a common cathode impedance such as the resistance  $R_4$ .

If the valve  $V_1$  is initially biased to cut-off, a rising positive voltage applied across the input terminals  $I$  will cause  $V_1$  to conduct so that its anode voltage falls. The resulting negative voltage transferred to the grid of  $V_2$  will cause that valve to cut-off, whereupon the valve  $V_1$  passes the full output. When the output voltage is reduced, the sequence is reversed and the full output is again delivered to the terminals  $O$ .

The winding of an electromagnetic relay may replace the anode resistance  $R_1$  lag or overlap between input and output voltages may be reduced by varying the time-constant or reactance of the intervalve couplings.

*Cinema-Television, Ltd., and T. Nuttall. Application date September 29th, 1941. No. 552301.*

## CATHODE-RAY TUBES

THE intensity of the electron stream through a cathode-ray tube is controlled by voltage applied to an impedance  $Z$  in the lead to the cathode  $K$ , where it is common both to the grid-cathode and anode-cathode circuits.

This reduces the shunt capacity of the tube, and so improves its response to the highest frequencies, as compared with the usual method of applying the input voltage direct to the control grid  $G$ . In the latter arrangement, the total input capacity consists of that shown

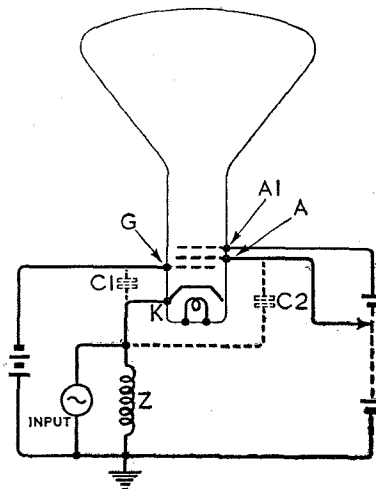

Cathode-controlled CR tube.

at  $C_1$ , plus the capacity between the grid  $G$  and the first anode  $A$ , both of which provide parallel shunts to earth.

In the arrangement shown, the total shunt capacity is the sum of the capacities  $C_1$  and  $C_2$ . The advantage arises from the fact that the capacity  $C_2$  is obviously much smaller than that existing between the control grid  $G$  and the anode  $A$ .

Since the control voltage across  $Z$  is also, in effect, applied to the first anode  $A$ , the overall slope of the tube is correspondingly increased. This serves to counteract the effect of the negative back-coupling introduced by the position of the impedance  $Z$ .

*Philips Lamps, Ltd. (communicated by N. V. Philips' Gloeilampenfabrieken). Application date October 14th, 1941. No. 552743.*

## REMOTE TUNING CONTROL

A SEMI-CONDUCTOR, such as a mixture of manganese and nickel oxides, having a high negative temperature coefficient of resistance, is connected, either in series or shunt, with a fixed reactance to form the variable element in a remote tuning-control system. The element is inserted as a whole, either in series or shunt with the main oscillatory circuit, the frequency of which is then controlled by indirectly heating the semiconductor, preferably by means of an auxiliary current.

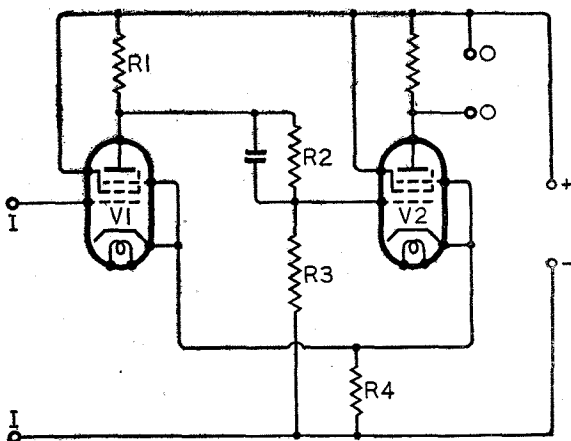

Relay trigger circuit.

DIRECTIONAL SYSTEMS

Alternatively, the semi-conductor is inserted in the cathode lead of a control valve whose grid-cathode capacity is shunted across the main oscillatory circuit. The frequency of the latter is then regulated from a distance through the known Miller effect by indirectly heating the semi-conductor, thereby altering the shunt reactance of the control valve.

*Standard Telephones and Cables, Ltd., and C. W. Earp. Application date October 3rd, 1941. No. 552431.*

TELEVISION IN COLOUR

SUCCESSIVE images, produced when the televised object is subjected, say, to red, blue, and green light, are radiated from the transmitter. These are reproduced in black and white by the receiver, and are viewed in rapid succession through colour filters, which are changed in synchrony with those used in transmission.

It is found, in practice, that the response of the photo-electric mosaic screen, forming part of the transmitting tube, is not equally sensitive to each of the three primary colours. In addition, other unbalanced effects can arise from inherent defects in the colour filters, as well as from the type of lighting used in the studio which may show an undue proportion either of red or blue energy.

In order to compensate for all such irregularities three auxiliary lamps, each emitting one of the primary colours, are arranged in front of the television transmitting camera, and on the object side of the ordinary colour disc. The intensity of the light from each lamp is separately adjustable, by hand or otherwise, to provide the extra floodlighting required to ensure the proper balance of colours in the picture as seen in the receiver.

*Marconi's Wireless Telegraph Co., Ltd. (Assignees of E. I. Anderson). Convention date (U.S.A.) February 11th, 1941 No. 553255.*

GASEOUS INSULATORS

THE dielectric properties of air, nitrogen and other gases are utilised in various electrical devices such as condensers and co-axial transmission lines.

It is known that dichloro-difluoromethane, commonly known as "freon," possesses the property of absorbing the energy of free electrons to a marked degree. This, of course, reduces the tendency of such electrons to ionise and so diminish the dielectric strength of any gas in which they may be present.

The inventors claim the use of any gaseous insulator containing up to 5 per cent. of "freon."

*Standard Telephones and Cables, Ltd. (Assignees of H. Skilling). Convention date (U.S.A.) November 27th, 1940. No. 553560.*

The British abstracts published here are prepared with the permission of the Controller of H.M. Stationery Office, from specifications obtained at the Patent Office, 25, Southampton Buildings, London, W.C.2, price 1/- each.

RELATES to direction finders of the kind in which two frame aeri-als, F, F1, set at right angles, are each connected through separate amplifiers, A, A1, to the deflecting plates of a cathode ray tube. Each amplifier is of the superhet type, and both are coupled to the same local oscillator. If the resulting trace is to give an accurate indication of the direction of the incoming signal it is essential that the two amplifiers should have identical characteristics, both as regards gain and phase-displacement.

In order to test the set in this respect, an auxiliary switch S allows both the aeri-als to be earthed through a common resistance, so that the same input signal can be applied to each of the amplifiers. In addition, one of the amplifiers is provided with independent gain-control and phase - adjusting means, B.

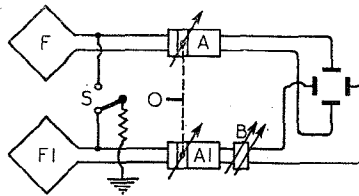

CR direction finder.

If, when the earthing switch is closed, the cathode ray trace appears as an ellipse, the gain and phase controls are adjusted until this is converted into a straight line. The amplifiers are then correctly balanced, and the testing switch can be opened for ordinary directional observation.

*Philips Lamps, Ltd. (communicated by N. V. Philips' Gloeilampenfabriek). Application date February 16th, 1942. No. 553618.*

PIEZO-ELECTRIC CRYSTALS

FOR operation at frequencies of 1,500 kc/s and upwards, a piezo-electric oscillator can be mounted between electrodes which also serve as clamps or supports. At lower frequencies, say of the order of 200 kc/s, the crystal is not usually clamped, but is arranged to rest freely on one electrode with a small air gap separating it from the other electrode. The relatively small "free" movement thus allowed may result in undesirable frequency fluctuations of as much as 20 to 30 cycles per second.

To avoid this source of irregularity a plate crystal is clamped between two or more pairs of two-diameter steel pins. Each pin has a comparatively large massive shank which is screwed or fixed to the main supporting frame, and a comparatively small and flexible continuation or "tine" which is pressed against and clamps the crystal in position.

The arrangement, in effect, forms a cantilever support, the dimensions of the flexible tine being calculated on known principles to have a resonant frequency equal to that of the crystal.

*F. D. Biley and C. Collman. Convention date (U.S.A.) July 1st, 1940. No. 552386.*

The Improved  
**VORTEXION**  
50 WATT  
AMPLIFIER CHASSIS

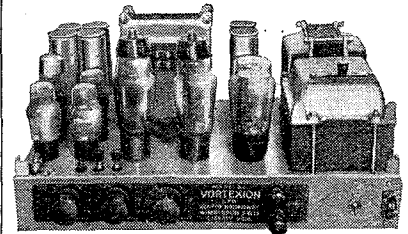

The new Vortexion 50 watt amplifier is the result of over seven years' development with valves of the 6L6 type. Every part of the circuit has been carefully developed, with the result that 50 watts is obtained after the output transformer at approximately 4% total distortion. Some idea of the efficiency of the output valves can be obtained from the fact that they draw only 60 ma. per pair no load, and 160 ma. full load anode current. Separate rectifiers are employed for anode and screen and a Westinghouse for bias.

The response curve is straight from 200 to 15,000 cycles. In the standard model the low frequency response has been purposely reduced to save damage to the speakers with which it may be used, due to excessive movement of the speech coil. Non-standard models should not be obtained unless used with special speakers loaded to three or four watts each.

A tone control is fitted, and the large eight-section output transformer is available in three types: 2-8-15-30 ohms; 4-15-30-60 ohms or 15-60-125-250 ohms. These output lines can be matched using all sections of windings and will deliver the full response to the loud speakers with extremely low overall harmonic distortion.

PRICE (with 807 etc. type valves) **£18.10.0**  
Plus 25% War Increase

**MANY HUNDREDS ALREADY IN USE**  
Supplied only against Government Contracts

**VORTEXION LTD.**

257, The Broadway, Wimbledon, S.W.19

'Phone: LIBerty 2814



# RANDOM RADIATIONS

By "DIALLIST"

## Quality at a Distance

FROM a reader who lives in the farthest parts of Cornwall comes a wail about the impossibility of obtaining good quality in the reproduction of broadcast programmes in such distant places. He proposes means of effecting an improvement and asks if I've any suggestions to make. I have. Lots! His idea, briefly, is this: It may be easy, says he, for those who live almost on the doorstep of a 50-kW station and use ten-valve receivers to obtain something that at any rate gives the impression of decent quality; but the listener in a far-off place can't have it, no matter what he does. Why, he asks, do I have to pick up and amplify *both* sidebands when it seldom happens that more than one of them is "spoilt by monkey chatter"? A single sideband, clean and clear, would make up to 10,000 cycles available for the loudspeaker. And he proposes to ensure that the single sideband, if supplied, would be clean and clear by using a six-foot frame aerial designed for very sharp minima. There is a lot to be said for single-sideband broadcasting and, unless my memory is at fault, P. P. Eckersley has said most of it. But the idea has not caught on and I do not think that it will. We shall have to find other solutions of the quality-at-a-distance problem. The one that appeals to me most is to cover the country with a network of small relay stations, transmitting with frequency modulation for choice. That, I believe, is what will eventually happen, for it seems to be the only way in which television can be brought into the homes of those who live far from the densely populated districts. As I see it, such stations as we have at present will continue to broadcast with AM for a considerable time and some will be retained for a very long time. But the place of the majority will gradually be taken by the low-powered FM network, combining speech and music with vision transmissions. Television will then be available to all who provide themselves with vision receivers. Those who either don't want them or can't afford them will have the speech and music for their entertainment. The great advantage of FM is that it makes high-quality transmission and reception possible and eliminates interference to a very large extent. It has to be done on very high frequencies. Therefore the range is limited and

the old mutual interference problems, which have hitherto made the evolution of international broadcast wavelength schemes so difficult, just disappear. The FM sound-cum-vision scheme, then, has a great deal to recommend it.

## Wired Broadcasting

The alternative—if it is strictly an alternative—is wired broadcasting, which has caused such a flutter in the dove-cotes of late. Whatever may be said for this kind of entertainment distribution, it will never meet the requirements of the large body of amateur radio enthusiasts. Their strength was considerable before the war; it will be vastly greater when peace comes back, for so many men and women in all the three Services have acquired a sound elementary (or even advanced) knowledge of the workings of radio and have developed a deep enthusiasm for it. Both the old hands and the wireless war-babies will be filled with the itch to have lots of knobs to twiddle and the burning desire to improve the performance of any apparatus that comes their way that are characteristic of the wireless fan. They will never be satisfied with "piped" broadcasting. As I have said, they will be a large body, and I think they will make themselves felt. I expect to see the wired system developed considerably, but I do not think it is going to oust ether-borne broadcasting, at any rate not for a very long time to come. There are some, I know, who think that the wireless set should be just as much a piece of furniture as the piano. Few people, with the exception of professional pianists or piano tuners, know much about the theory or the inner workings of the instrument, or tune or adjust their own pianos. Why, then, say the supporters of wired broadcasting, should the ordinary person bother his head over the innards of the radio receiver or care two hoots about wireless problems? If by the "ordinary person" they mean he or she who neither knows nor cares anything about wireless, I agree wholeheartedly. But, as I have shown, the number of people back in civil life when the war is ended who do know something and do care a lot is going to be very large. Everybody wants and needs a hobby, and wireless is going to be the hobby of a far bigger section of our people than has ever previously been the case. Lots of these people have had a good deal

to do with cathode-ray tubes, and television will be just meat and drink to them. Wired broadcasting probably would not give them that, and certainly it would not give them the scope that their enthusiasm for real radio craves. An FM and television relay network seems to me to be by far the best way of satisfying everyone's demand.

□ □ □

## Drinking It In

WHAT people in the Army (and I am sure it is true of the other Services) have learned about wireless during the war is almost incredible. One of the best radio mechanics that I have had was in civil life a crofter in the far north of Scotland. His home is more than 60 miles from the nearest railway station and such things as electricity in general, and wireless in particular, were complete mysteries to him in 1939. Nor had he ever used any but the simplest of tools. To-day he will trace a fault in a highly complex piece of electrical apparatus and put it right. He has a respectable knowledge of theory and a burning enthusiasm for all departments of wireless. He is a first-rate hand at small, neat soldering jobs and a good all-round mechanic. Then I know girls who as soon as they look at you will discuss the mathematical analysis of detection or bowl you fast ones in the shape of questions on aerial theory. Yes, the number of girls who have taken to Radar and other departments of wireless as ducks take to water is remarkable. I have had hundreds of them through my hands and all—but a very small percentage work like niggers, are as keen as mustard and just drink in what you teach them. Many of them, I believe, will be real radio fans when they return to civil life.

## Service-men

One thing we should not be short of when the war is over is good radio service-men. Thousands have had a very thorough training in wartime, and after the complicated gadgets with which they have had to deal the ordinary broadcast receiver, mains or battery, that needs an overhaul will be just money for old rope to them. Before the war the really efficient service-man was far too rare. Too many were just dabblers, who found anything but the simplest fault beyond them. I have come across instances of sets returned to the makers for repair—and needless expense imposed on



their owners—on account of break-downs of the most elementary kind; troubles that could have been tracked down quickly and set right by any moderately competent man. We shall have no more of this kind of thing, for properly trained men will be available. And they will be duly qualified, too, if the theoretical and practical exam. inaugurated by the Radio Trades Examination Board receives the backing that it deserves.

□ □ □

### HT Batteries

THE distribution of radio HT batteries still seems to be rather unsatisfactory. There are places where you can buy them as easily as shelling peas and others where they are rarer than eggs. Curiously enough, the localities where they are most readily available are often towns, where, presumably, the majority of receivers are mains-operated. The greatest need for them is in villages and hamlets where there is no electric light, and consequently all sets are battery-operated. And it is just in the out-of-the-way parts of the country that they are scarcest. The position should be looked into without delay, for many people go weeks without wireless because they cannot obtain HTBs. Why, I wonder, do we still retain the term "tension"? I believe we borrowed it from the French many years ago. I suppose we will go on using it; though as we speak of grid batteries and filament batteries I would have thought that plate battery was simpler. The Americans have simplified things to the utmost by speaking of A batteries (filament), B batteries (plate) and C batteries (grid). We might do worse than add these terms to our borrowings from them.

### "WIRELESS WORLD" DIARY, 1944

THIS annual publication, issued from these offices, is now ready. In addition to the usual features of a pocket diary, it contains a 77-page reference section, which has again been revised. As supplies are limited, our publishers advise readers to obtain copies without delay from a bookseller, bookstall or stationer. The price, including purchase tax, is 3s. 1d.

### THE WIRELESS INDUSTRY

THE Twickenham office (13a, King Street) of the Edison Swan Electric Company has now been closed and the staff has returned to 155, Charing Cross Road, London, W.C.2.

An illustrated brochure giving technical information about "Mycalex" insulating material has recently been issued by the Mycalex Co., Ltd., Ashcroft Road, Cirencester.

## COMMUNICATIONS DEPEND...

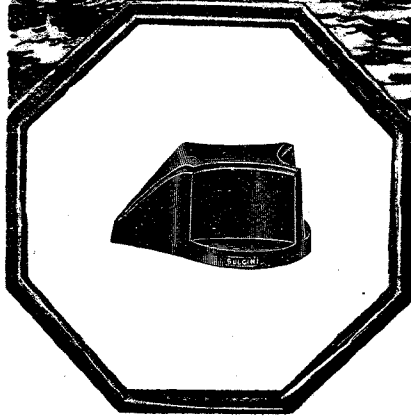
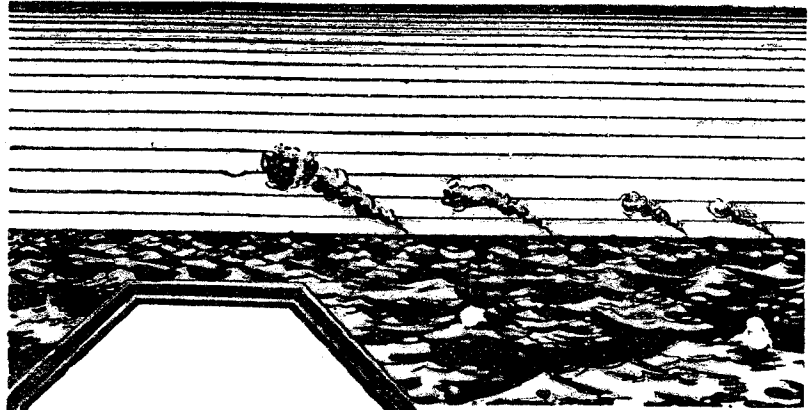

## ON SMALL PARTS...

IN countless instances quite intricate pieces of apparatus are wholly dependent on the proved reputation and reliability of their component parts.

All products from the House of Bulgin are pre-eminent for superior design and workmanship and every article bearing our Trade Mark has to pass exacting and exhaustive tests during the course of its production.

We ask the kind indulgence of the Trade on delivery until peaceful conditions return.

*The Choice of Critics*

### BULGIN FOR KNOBS

*The largest and most extensive range in the world. Over fifty models from which to choose. All sizes and shapes, for different classes of work or operation. Nearly every type has brass-insert, steel grub-screws are fitted, well sunk. For 0.25in. dia. shafts and other sizes. Finely moulded and highly polished. The highest class instruments use Bulgin Knobs exclusively.*

**"The Choice of Critics"**

# BULGIN

REGISTERED • TRADE • MARK

A. F. BULGIN & CO. LTD., BYE PASS RD., BARKING,

TEL. : RIPPLEWAY 3474 (4 lines).

ESSEX

# UNBIASED

## "Aux Armes"

IT is astonishing how swiftly came complete vindication of the words I wrote last month to the effect that plans were being made by the mandarins and moguls of St. Martin's-le-Grand to impose upon us after the war a system of "conducted carrier" broadcasting over the network of gaspipes which are still the sole conductors of laid-on light and heat to a great many of the houses in our larger cities and towns. Scarcely had I laid my pen aside and despatched my manuscript to the Editor than there came the official announcement of the appointment of the erstwhile chief of a famous gas company to the all-powerful position of sole Director-General of the B.B.C.

The old saying that whom the gods would destroy they first make mad seems particularly applicable to certain wireless men who seem so concerned with debating the technical issues that they quite fail to realise that unless the political aspect of this question is tackled they will soon have no technical problems to wrangle over. Even in the technical field I am ashamed to see wireless engineers of repute giving voice to the opinion that the "wired" system is capable of giving better quality and less interference than its ether-borne counterpart. If, in 1896 or thereabouts, automobile engineers had admitted publicly that horse-drawn vehicles were more dependable and capable of giving better service than cars, where would our luxury limousines be to-day? No, they kept their real opinions to themselves and set to work quietly to make their publicly expressed views come true, and radio men would do well to emulate their example and remember the old Scottish proverb that it is an ill bird that fouls its own nest.

In order to realise the full implications of this country going

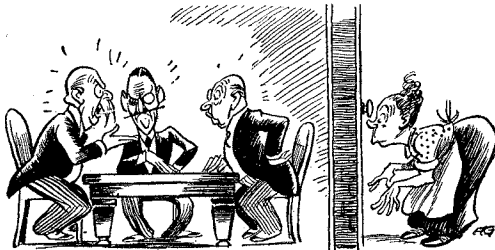

Engaged on intimate work.

"all-wired," and, therefore, totalitarian in its broadcast listening, it is only necessary to imagine what

By

## FREE GRID

would have happened if this proposed regimentation of our aural pleasures had been in existence in 1939. It is certain that one of the programmes that would *not* have been fed to us would have been the one provided daily by Lord Haw-Haw, which has become one of the bright and amusing spots that liven up the drab grey of the dry and dreary wastes of the B.B.C.'s ponderous efforts to educate, inform, and uplift us. In fact, I feel so strongly about the way he managed to keep us cheerful in the "wee small hours of the war" when there didn't seem much to be cheerful about that I hope he won't be forgotten when the victory honours list is published and Mr. Bevin is forced to direct many erstwhile war workers into the factories of the hard-pressed makers of coronets and other insignia of nobility.

The establishment of a "wired" broadcasting service in this country would only be the thin edge of the wedge, for gaspipes would eventually give place to AC mains, and it would be then that our real days of slavery would begin. I have it on the authority of one who is employed on very intimate work in the household of a high Government official that plans are already afoot to mass-produce AC clocks and to emulate the feat of Abanazar in "Aladdin" and offer these in exchange for the old "clockwork" or mechanical time-pieces of our households.

The idea is simple. Since we should have no wireless sets we should have no chance of listening to time signals from abroad and should be dependent on the Government grid-controlled clocks. It will

then be a simple matter for those in authority to arrange for the AC frequency to be deliberately lowered in the daytime, so slowing down our clocks, and for the reverse process to be applied at night, thus getting extra working hours out of us without our knowledge. It behoves us, therefore, to sink our petty differences and rally behind the Editor in his campaign. *Aux armes, mes amis.*

## What the Sunspots Foretell

THE full significance of the fact that, as explained in the October issue of *Wireless World*, the present sunspot cycle is apparently drawing to a premature close now, instead of next year, is probably appreciated by comparatively few readers. On those few, however, it will without doubt have the same effect as it has had on me and cause them to search feverishly in their attics and lumber rooms for their long-disused television sets. If one of the Editor's correspondents is to be believed, it means nothing more nor less than the imminent down-

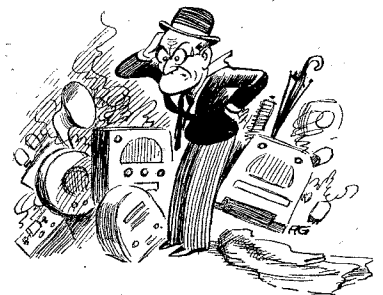

Feverishly searching.

fall of Adolf and all that he stands for.

I am no astrologer, but I could not help but be struck by the significance of the facts pointed out by this correspondent, whose letter the Editor published in the March, 1942, issue of this very factual journal under the attention-compelling title of "What the Sunspots Foretell." The letter in question pointed out the remarkable phase relationship between the curve of the present sunspot cycle and that tracing the Adolf-appeasement cycle.

It was on January 30th, 1933, that Adolf commenced his rise to infamy, and it was about that time that the present dying sunspot cycle commenced to rise, reaching its maximum height in 1937-8, when the Adolf-appeasement curve also reached its maximum. In 1939 came the outbreak of war, and with it the steady decline of both the sunspot and the appeasement curves. Is it too much, therefore, to hope that this is not mere coincidence, but that there is, as the Editor's correspondent intimated, some esoteric connection between the two curves and that we may hope ere long to see our television receivers aglow with life once more?